

1ST TRANSMITTAL REVISE & RESUBMIT WARRANTY SHOP FABRICATION

PART NUMBER			QTY
DI***		24"Ø Chute: -(1)TRASH -16ga -Galvanneal	1
14311I	1	24"Ø x 72" Intake Section.- See Detail Sheet (Page #2) -WITH Sound Dampening (Daubert 932) -WITH Companion Clip at Bottom (1)	2
2584NB 91A067	2	15"x18" BOTTOM HINGED. -See detail sheet (Page #2) -HAND OPERATED *Thumb latch and trigger -Stainless Steel FOUR piece trim (RUBBISH)	2
20015D	3	Discharge Door - See detail sheet (Page #2) -Type "A": Horizontal Insulated Sliding Steel door held open by fusible link.	1
14411T	4	24"Ø x 48" Pipe - WITH Sound Dampening (Daubert 932)	1
14412T	4A	24"Ø x 48" Pipe - WITHOUT Sound Dampening .	3
14311T	5	24"Ø x 36" Pipe - WITH Sound Dampening . (Daubert 932) -WITH Companion Clips at Top & Bottom (1)	2
14212T	6	24"Ø x 24" Pipe - WITHOUT Sound Dampening .	1
14112Z	7	24"Ø x 12" Pipe - WITHOUT Sound Dampening -With Flushing Spray Head. 3/4 " IPS flushing spray head assembled in 12" pipe section located above top intake ready for connection by others.	1
14043W	8	Floor Frames. -See detail sheet (Page #3)	3
91F006	9	Sprinkler Heads. -See detail sheet. (Page #3) Located at Floors: 2 & 1	2
1441SV	10	Full Diameter Vent With Flat Flashing W/SCREEN.	1
91B002	11	Mason Isolator Pad. -Four Pieces for each floor frame.	12
91A002	12	Disinfecting and Sanitizing Unit. -See detail sheet (Page #3)	1
2554NY 91A038	13	15"x15" RHDR. -See detail sheet (Page #2) -HAND OPERATED *T- Handle Lock -Stainless Steel FOUR piece trim	1

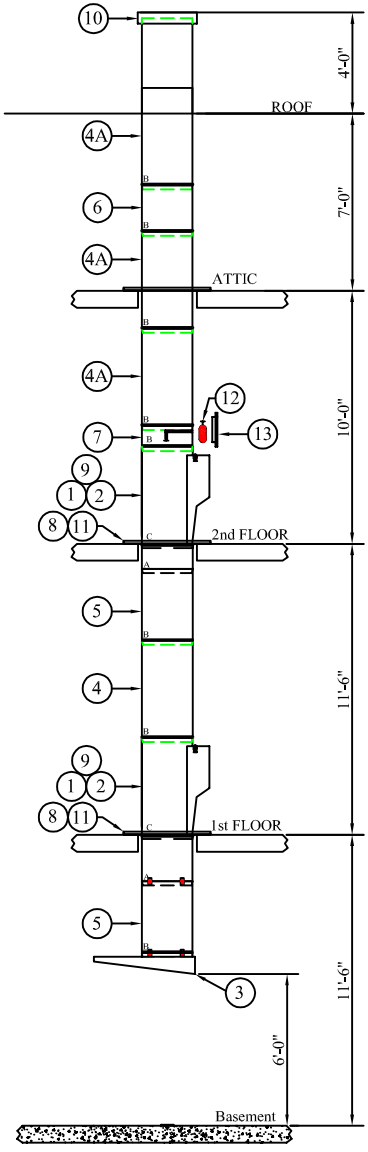

DESCRIPTION	REV.	DATE	INIT.
		*****	****

This Drawing is the property of WILKINSON HI-RISE. It is loaned on the condition that it is not to be reproduced, copied or otherwise disposed of, and is not to be used in part to furnish information for the making of drawings, prints, or parts there of. the acceptance of the foregoing conditions and the recognition of the exclusive ownership in and to the drawings as the property of WILKINSON HI-RISE.

Job: TYPICAL TRASH CHUTE
Address:
Job # :

WILKINSON-HI-RISE
3001 Greene Street
Hollywood, FL 33020
Tel: 800 231 3888

CUSTOMER: *****

DWG. CH-003 SCALE NTS SHEET 1 OF 3

1

2

3

4

5

6

7

8

1ST TRANSMITTAL REVISE & RESUBMIT WARRANTY SHOP FABRICATION

GENERAL NOTES:

- 1. All Chutes to have Wilkinson type vertical lock-seams and inside lap round-about joint. See Detail Sheet. (Or, whatever we reference the detail info in the shop drawings)
- 2. All cutting of floors, walls, or roof to allow for chute installation to be done by others.
- 3. Chute venting per NFPA 82 - Full size vent extending 3 ft. above finished roof.
- 4. Wilkinson Hi-Rise complies with all NFPA guidelines and accepts no responsibility for the deviation of these standards by local codes or ordinances.

CHUTE DOOR DETAIL

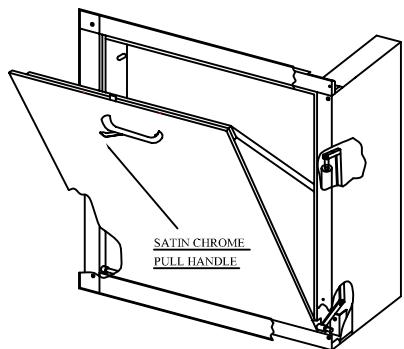

UL RATED 1 1/2 HR. "B" LABEL

ACCESS DOOR DETAIL

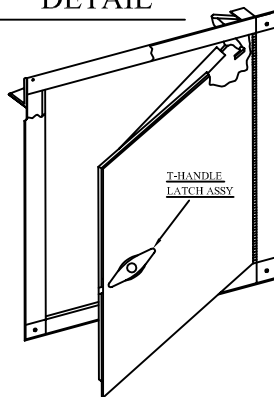

UL RATED 1 1/2 HR. "B" LABEL

ROLLING DOOR

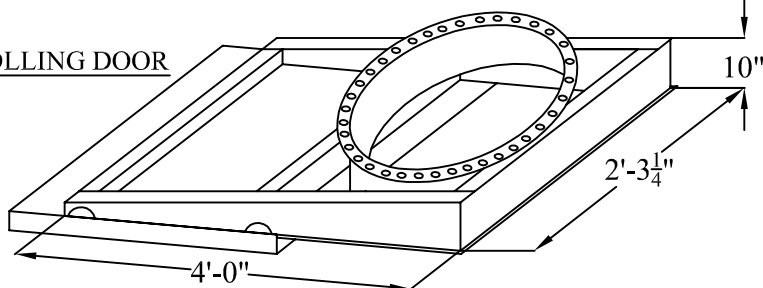

DISCHARGE A

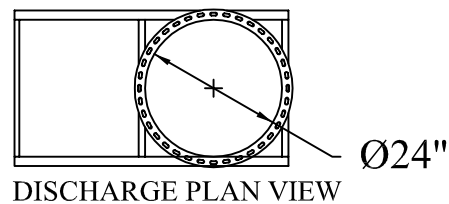

DISCHARGE TYPE "A" DETAIL

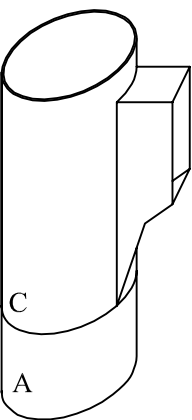

INTAKE DETAIL

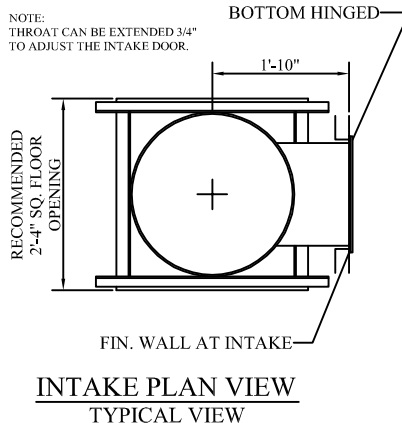

CENTERLINE OF CHUTE TO OUTSIDE FINISHED FACE OF WALL

SEE ITEM #9 IN B.O.M.

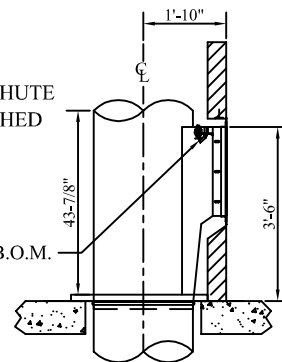

WILKINSON-HI-RISE

3001 Greene Street
Hollywood, FL 33020
Tel: 800 231 3888

This Drawing is the property of WILKINSON HI-RISE. It is loaned on the condition that it is not to be reproduced, copied or otherwise disposed of, and is not to be used in part to furnish information for the making of drawings, prints, or parts there of, the acceptance of the foregoing conditions and the recognition of the exclusive ownership in and to the drawings as the property of WILKINSON HI-RISE.

Job: TYPICAL TRASH CHUTE

Address:

Job #:

CUSTOMER: *****

DWG. CH-003

SCALE NTS

SHEET 2 OF 3

1

2

3

4

5

6

7

8

1ST TRANSMITTAL REVISE & RESUBMIT WARRANTY SHOP FABRICATION

FIELD NOTE
 ENCLOSING WALLS AROUND CHUTES ARE NOT TO BE ERECTED UNTIL AFTER CHUTE IS INSTALLED
NOTE
 CONTRACTOR TO VERIFY AND APPROVE ALL DIMENSIONS ON THIS DRAWING WITH CONDITIONS AT THE JOB SITE. WILKINSON IS NOT RESPONSIBLE FOR DEVIATIONS FROM THIS DRAWING ONCE APPROVED

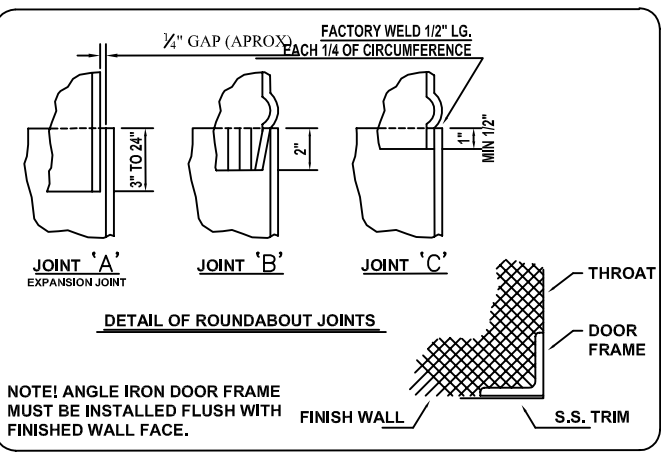
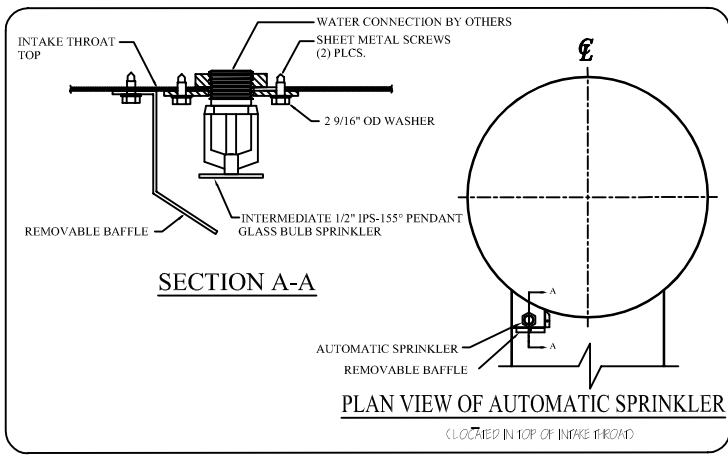
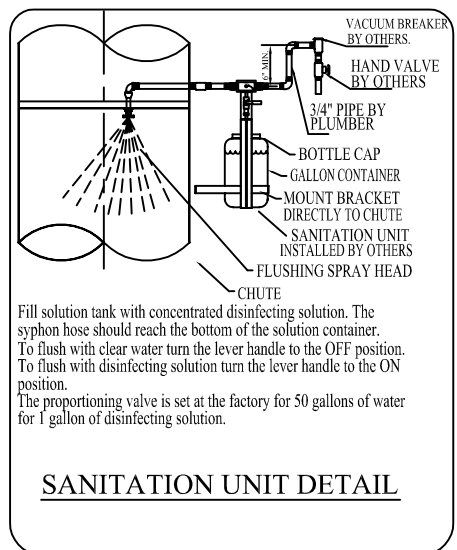
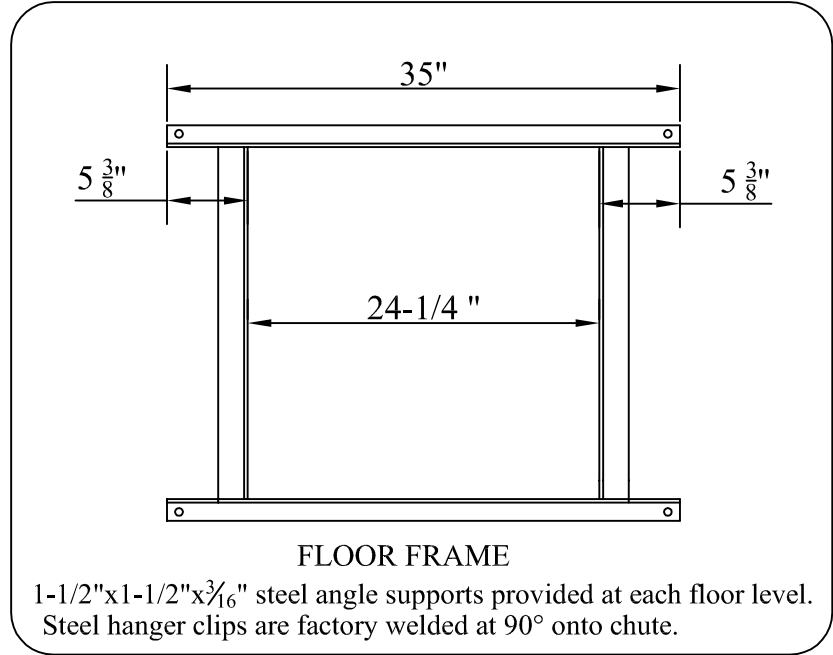
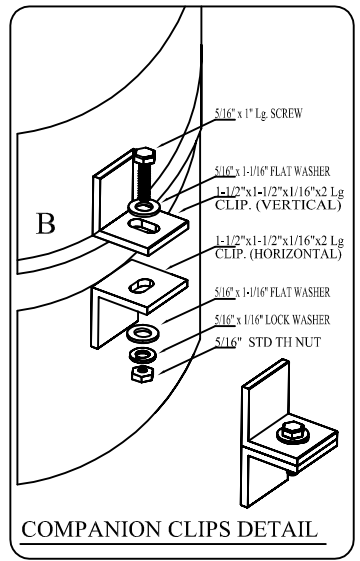
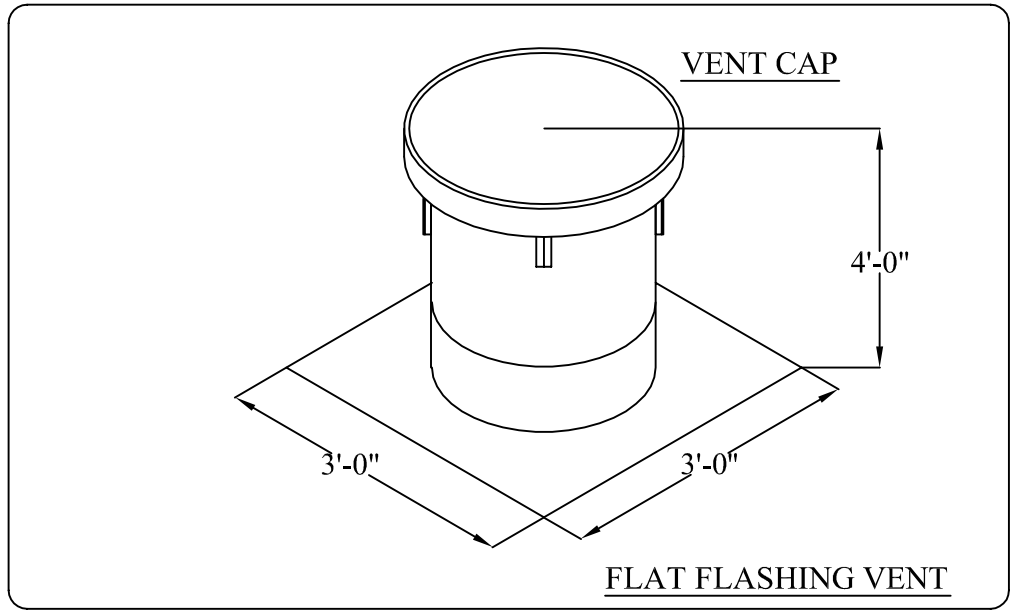

WILKINSON-HI-RISE
 3001 Greene Street
 Hollywood, FL 33020
 Tel: 800 231 3888

This Drawing is the property of WILKINSON HI-RISE. It is loaned on the condition that it is not to be reproduced, copied or otherwise disposed of, and is not to be used in part to furnish information for the making of drawings, prints, or parts there of, the acceptance of the foregoing conditions and the recognition of the exclusive ownership in and to the drawings as the property of WILKINSON HI-RISE.

Job: TYPICAL TRASH CHUTE
Address:
Job # : *****

CUSTOMER: *****
DWG. CH-003 **SCALE NTS** **SHEET 3 OF 3**