



**WILKINSON HI-RISE**  
CHUTE MANUFACTURERS SINCE 1923

Wilkinson Hi-Rise dba WHR Holdings  
3402 SW 26<sup>th</sup> Terrace Unit B-10  
Dania Beach, FL 33312 (954) 342-4400

# DOOR MANAGEMENT SYSTEM

# ( D M S )

Installation,

Setup

and Operation Manual

## **Table of Contents**

Section 1:	USING THIS MANUAL
Section 2:	EQUIPMENT SAFETY
Section 3:	SYSTEM DESCRIPTION
Section 4:	ON SITE INSTALLATION
Section 5:	CONFIGURATION
Section 6:	SYSTEM OPERATION
Section 7:	TROUBLESHOOTING AND MAINTENANCE
Section 8:	SCHEMATICS AND DRAWINGS

# 1. USING THIS MANUAL

## A. INSTRUCTION MANUAL

This document contains the Manual for Wilkinson Hi-Rise's (*now referred to as Wilkinson*) **Door Management Systems** (now referred to as DMS). This manual is divided into eight (8) basic sections:

1. Using this Manual – Instruction Sheet to understand contents of the manual.
2. Equipment Safety – Lists all Basic Required Safety requirements.
3. System Description – Explains the Basic Components of the System.
4. On Site Installation – Covers the recommended installation guidelines.
5. Configuration – Procedures to configure major function of the system.
6. System Operation – Covers normal operation of the system.
7. Troubleshooting and Maintenance – Self-explanatory.
8. Schematics and Drawings – Self-explanatory.

## B. SPECIAL ATTENTION BOXES

*Throughout this manual, special attention boxes are provided to supplement the instructions and make special notice of potential hazards and important aspects of the operation of the system. The definition of these special attention boxes is as follows:*

### **WARNING !!!**

*Indicates a condition or hazard, which will cause severe personal injury, death or property damage.*

### **NOTICE !!!**

*The special attention box contains information pertaining the system.*

## C. LOCATION OF THIS MANUAL

*WILKINSON strongly advises that the end user reads this manual prior to operating the system; And to have this accessible to maintenance and operators of the equipment.*

*If there is any service required to the unit, make sure it is performed by trained personnel only. If required contact WILKINSON for technical support and advise on how to get your system in working condition*

## 2. EQUIPMENT SAFETY

1. MOUNT THE COPY OF THIS PAGE THE TRASH ROOM.
2. WHENEVER ANY MAINTENANCE OR SERVICE IS TO BE PERFORMED ON THE TRASH CHUTE SYSTEM, THE ENTIRE SYSTEM SHOULD BE TAKEN OUT OF SERVICE BY PUTTING THE SYSTEM IN **SERVICE MODE** - LOCKING ALL OF THE INTAKE DOORS ON THE CHUTE.
3. NEVER ATTEMPT TO WASH OR PRESSURE WASH THE AREA WHERE THE DMS CONTROLLER IS LOCATED, ALTOUGH IS NEMA 3 PROTECTED, DISCONNECT POWER TO AVOID ANY RISK OF WATER SHORT DAMAGE ON THE SYSTEM.
4. WHEN ICD DOORS INSTALLED ON THE CHUTE, NEEDS MAINTENANCE TO BE PERFORMED, ALWAYS MAKE SURE POWER IS DISCONNECTED AND OBSERVE THE REQUIRED LOCK/TAG OUT GUIDELINES OF YOUR BUILDING.
5. THE DMS CONTROLLER IS NOT SERVICEABLE BY THE EN USER AND IS NOT REQUIRED TO OPEN IT. IF THERE IS ANY ISSUE ALWAYS CONTACT WILKINSON REPRESENTATIVE FOR TROUBLESHOOTING.
6. NEVER PLACE ANY PORTION OF THE BODY INSIDE THE AREA OF THE DISCHARGE OF THE TRASH CHUTE. DEBRIS OR GARBAGE EXITING THE TRASH CHUTE MAY CAUSE SERIOUS BODILY INJURY OR DEATH.
7. ALWAYS WEAR SAFETY GLASSES, GLOVES, STEEL-TIPPED SHOES, AND A HARD HAT WHEN MAINTAINING THE TRASH CHUTE SYSTEM.
8. NEVER CLIMB OR REACH INTO THE TRASH CHUTE TO RETRIEVE OBJECTS OR ARTICLES.
9. COMPLY WITH ALL APPLICABLE REQUIREMENTS OF THE FOLLOWING DOCUMENTS:
  - a) LATEST ANSI Z245.1 SAFETY REQUIREMENTS FOR REFUSE COLLECTION AND COMPACTION EQUIPMENT.
  - b) ANSI A12.1-1973 - SAFETY REQUIREMENTS FOR FLOOR AND WALL OPENINGS, RAILINGS AND TOE BOARDS.
  - c) OCCUPATIONAL HEALTH AND SAFETY ACT- (OSHA)

## 3. SYSTEM DESCRIPTION

### 3.1. GENERAL

The Wilkinson **Door Management System, DMS**, is a flexible system designed to fulfill the needs of a Door Monitoring System, System Interlock or Safety Lockout on trash / linen Chute Systems. Including additional service options like chute clean/flush activation and Remote Monitoring when internet connectivity is enabled.

### 3.2. COMPONENTS

The System main components installed on a typical trash/linen chute application are:

- **Trash/Linen Chute** – This is the required environment where the disposal of trash or soiled linen happens. On a Vertical Gravity Operated Chute each level on a building is furnished with an Intake Door.
- **ICD Doors** – installed on each building level using a unique address set on each and interconnected via Cat6 EtherCAN Cable to communicate to the DMS Controller at the Trash room location.
- **DMS Controller** - Installed in the Trash Discharge Room it provides power to all doors on the building and provides the user interface for the user.
- **Internet Interface** – Is the accessory to interface the Ethernet to WIFI connection at the Trash Room for signal Stability.



### 3.3 EXTERNAL INTERFACES

In addition to door connections provided for control and monitoring, the DMS System can be linked to external system components such as

- Wilkinson Configured Compactor
- Fire Sensors such as Smoke or Heat Detector
- Third Party Building Management Systems
- Third Part Fire Alarm Systems

The interaction of these systems is configured to send and receive signals as well as to lock down the System upon an external signal Received. Contact Wilkinson for further Instructions.

### 3.4. CONTROLLER USER INTERFACE

The controller interface integrates a display to show system status, alarms, and access to the configurations settings. An integrated keypad is used to navigate the system as well as to enter information.

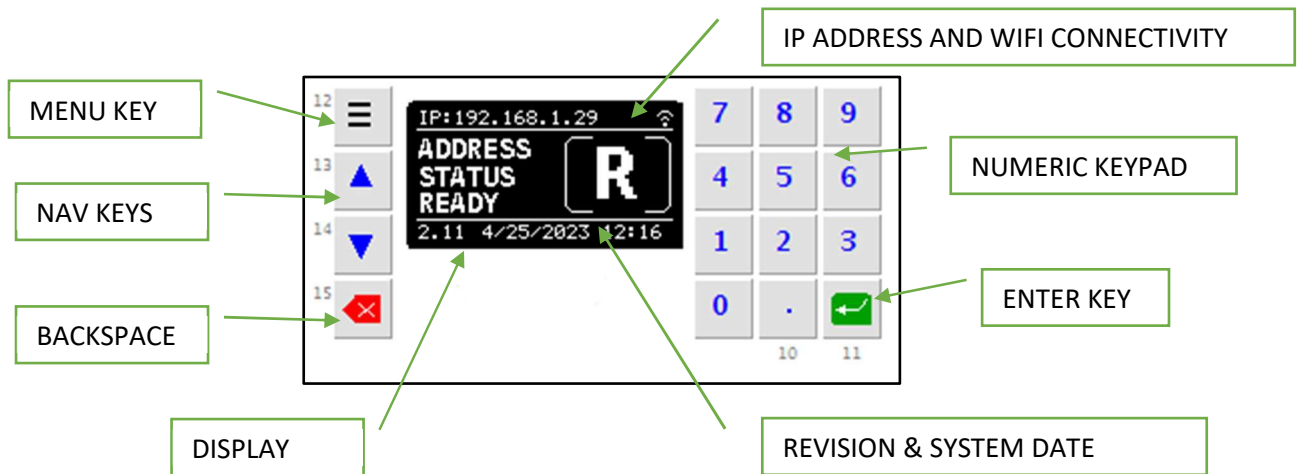

Controller Display can be dimmed or turned off if no Key Input or door Input is received within 10 minutes.

The Menu Key located at the upper left corner is used to Return or Restart a process routing or configuration.

Navigation Keys UP / Down Arrows are used to navigate through the menu options for selection. Usually Menus are numbered, you can use the navigation keys to move around or use a shortcut by pressing the number of the option desired to be selected. Once Selection is done press the ENTER KEY (Lower Right Corner Key)

Backspace Key (Lower Left Corner) is used to correct an entry on a data box.

### 3.5. SYSTEM MODES

The system has three main operational modes. This can be selected from the Main display using the UP [13] and DOWN [14] arrow keys to highlight the option and then press the ENTER KEY [11].

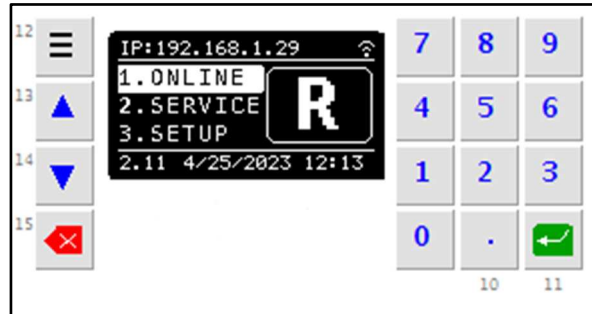

#### 3.5.1 ONLINE MODE

On this configuration, the system is actively listening for signals from the Doors Connected to the Controller as well to any other interface defined, the large [ R ] symbol displayed means that is **Ready**. By Pressing the MENU Key [12], the main menu will appear showing the other two operational modes.

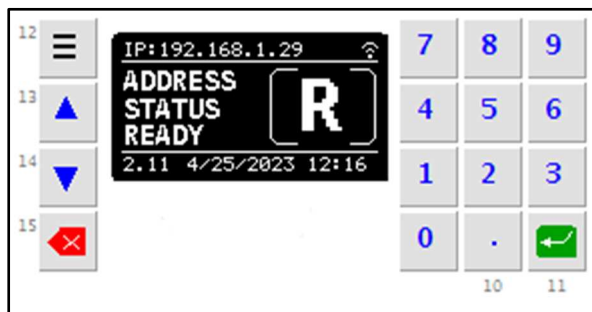

#### 3.5.2 SERVICE AND SETUP MODE

On these modes, the system is unable to receive signal from the doors, the large, enclosed letter "S" indicates that system is not accepting signals from the Doors during service mode or an ongoing setup routine. More Details about this in Chapters 5 Configuration and Chapter 6 System Operation.

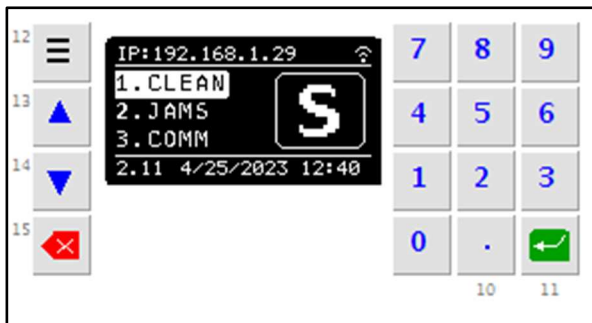

SERVICE MODE INTERFACE

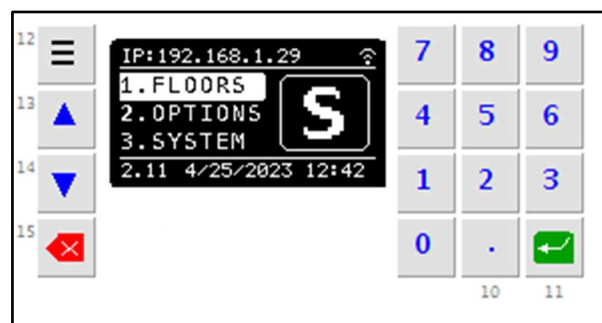

SETUP (CONFIGURATION) INTERFACE

## 4. On Site Installation

### 4.1. SAFETY FIRST...

#### **WARNING !!!**

*Only experienced personnel should attempt to install, service, or operate this equipment. Installing this equipment requires the installer to work with high voltage electrical connections, which can cause serious injury or death.*

#### **WARNING !!!**

*The following instructions are general guidelines on the installation of the controller system, always refer to your local authority for the applicable rules and regulations. Wilkinson Shop Drawings, Layout Data and related technical documentation is used as References.*

### 4.2. LOCATION AND INSTALLATION

1. Locate the controller as close to the Chute as possible without being able to interfere with the free fall of disposals or the movement of people or containers.
2. The System uses an American Style AC – Grounded Electrical Plug do not attempt to cut, replace, rewire or similar modification as this might void its warranty.
3. Install an Electrical Outlet for 110-127 VAC close to the Controller Location, make sure this breaker is dedicated to this Outlet and protected for a 10 A Fuse.
4. The Internet Interface is required to be installed as close as possible to the Controller to enable internet connectivity. Building Ethernet Setup might be required.
5. install the 4 attached mounting brackets by securing them to the back of the controller box prior mounting it.
6. Secure the Controller to the wall using the appropriate anchoring method as per the field condition and building standards.
7. Connect the power cord to the installed dedicated power outlet, connect the Ethernet Cable from the Doors to the Ethernet Port at the bottom of the controller. Proceed to Configuration.

## 5. CONFIGURATION

### **WARNING !!!**

*DMS Configuration is password protected, Ask Wilkinson representative for the passcode. Changes can affect the behavior of the operation of the doors, do not change it without further consultation.*

### 5.1 ENTER ON SETUP MODE

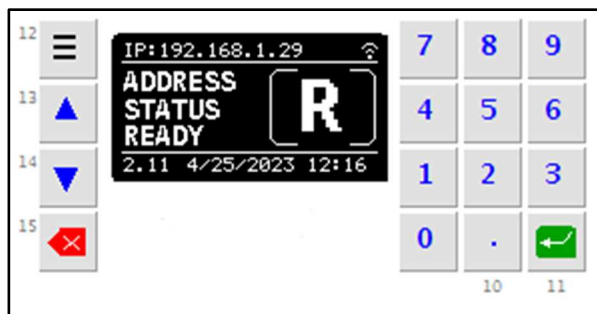

From the Standby Ready Screen, Press the MENU Key to display the three operation modes. To Return to the previous screen, always press the Menu Button.

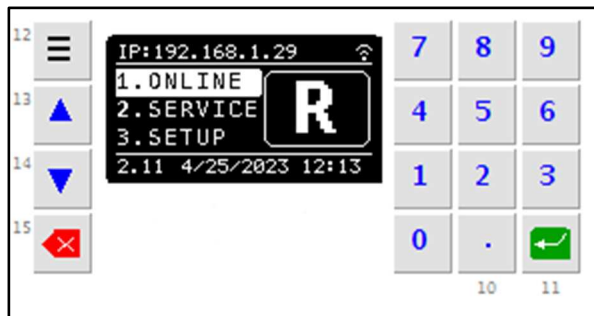

The Three options will appear, Letter R will indicate that system still on the Running mode until you select an option:

- 1) Online = Return to System Ready Screen
- 2) Service = Go to the System Service Option
- 3) SETUP = Enter to the System SETUP

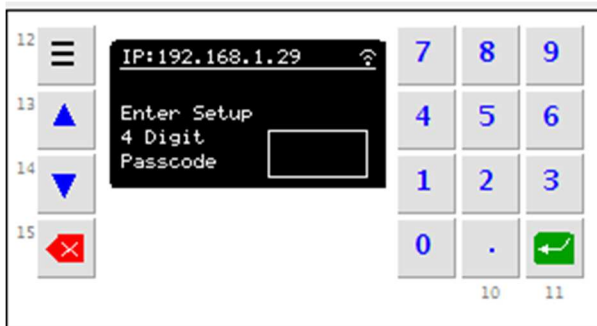

Upon Selection of 3 Setup then ENTER, the system will ask for the 4 Digit PASSCODE to enter the Configuration.

**Upon password acceptance, ALL Doors now will be LOCK.**

Leaving the System NOT ONLINE for certain period, will trigger and alarm and will send an email notification warning of such condition, when done with the configuration, press the MENU Button to return to the appropriate operation mode.

## 5.2 SETUP MODE

The Setup mode is critical to the operation of the system, an improperly configured system can render an unstable system. The System Setup is divided on 3 sections:

- 1) **FLOORS** = Manages, all information related to the connected doors to the DMS
- 2) **OPTIONS** = Manages, the Optional Components with interface to the DMS
- 3) **SYSTEM** = Manages System related operation for internet connectivity etc.

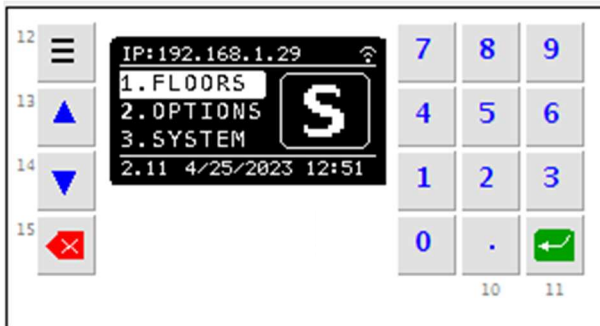

As previous explained, use the navigation key arrows to select the option or use the shortcut numbers

The Large [ S ] on the rectangular shape indicates that all doors are lock (red Light) on each keypad at the doors.

### 5.2.1 FLOORS

The Floors Menu is a dual option extends from options 1 to 8, use the arrow keys down to move from the first page of the menu to the next one and previous as needed. By pressing ENTER upon selection will display the selected configuration screen.

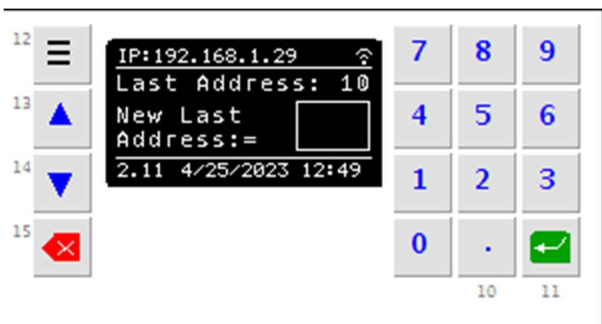
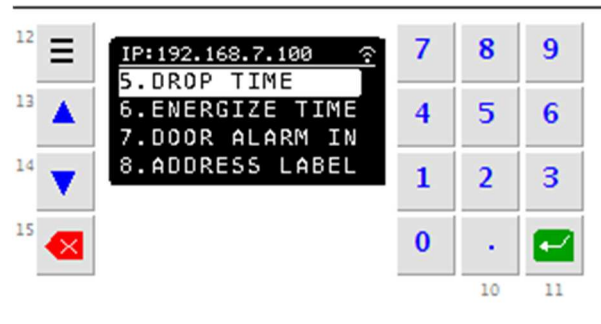
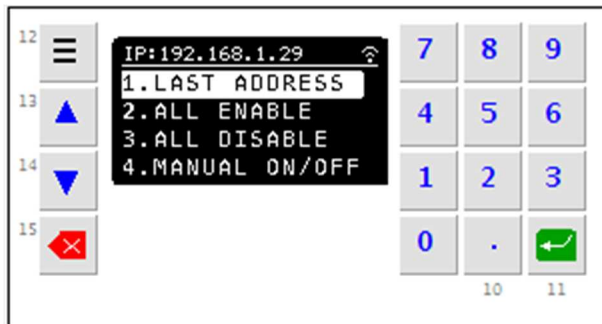

#### 5.2.1.1 – LAST ADDRESS

This indicates the Last Board Address on the System. Boards with addresses above this will be ignored. Last Address shows the current number, use the Keypad to enter the New Address as needed and press the ENTER Key.

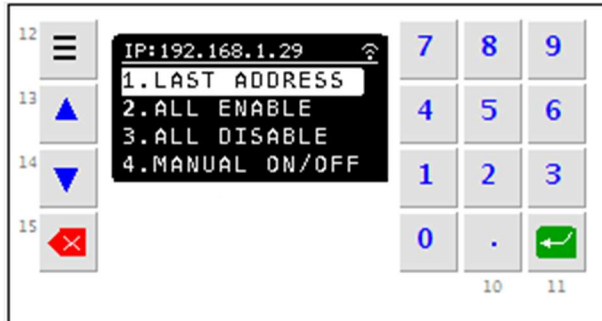

### 5.2.1.2/3 – ALL ENABLE/DISABLE

Addresses can be activated or deactivated as needed.

**ALL ENABLE** to turn ON all addresses from 0 – Top Floor,

**ALL DISABLE** will turn OFF all addresses from 0 – Top Floor,

**MANUAL ON/OFF** – see below.

### 5.2.1.4 MANUAL ON/OFF - INDIVIDUAL ADDRESS

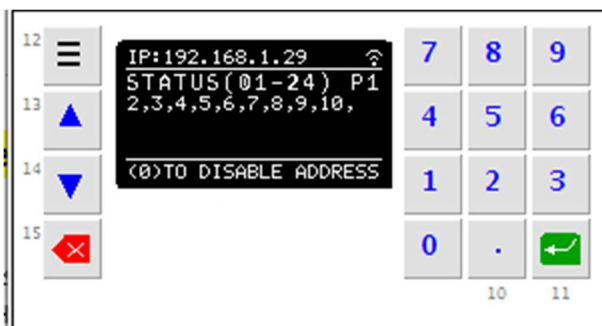

Individual addresses can be turned ON/OFF due to specific maintenance or management issues.

The Screen will show you the current enabled address in sections, use the Arrow Keys to navigate all pages until the 99 Maximum Address.

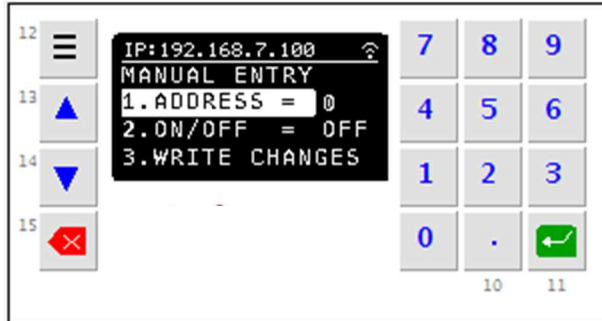

Press the Keyboard Key [ 0 ] this screen will appear displaying the options to change the status of an individual address.

Always use all options in sequence, being the last option the one that will set those changes on the configuration.

### RECOMMENDATION

When changing the TOP ADDRESS Setting, and to avoid Memory mismatch issues on the configurations do the following.

- 1) Select the option “ALL DISABLE”
- 2) Change the Top Floor
- 3) Select the Option “ALL ENABLE”
- 4) Optionally Disable any independent address
- 5) Reboot the system.

### 5.2.1.5 DROP TIME MENU

Drop time is the “wait time” of the controller to allow the use of the system by another address. This time allows the Disposal to travel by gravity down the chute and avoid another user to be injured by the failing disposal.

Drop time is assigned by Groups, in seconds, **LOAD DEFAULT** is the option to set the factory predetermined times per group.

Given Field conditions such, Different level to address assignments, increased floor-floor elevations, use of Additional Systems etc., you can also enter the **MANUAL ENTRY** Option to assign new values in Seconds. This must be Field verified and note that this will be specific to your field conditions.

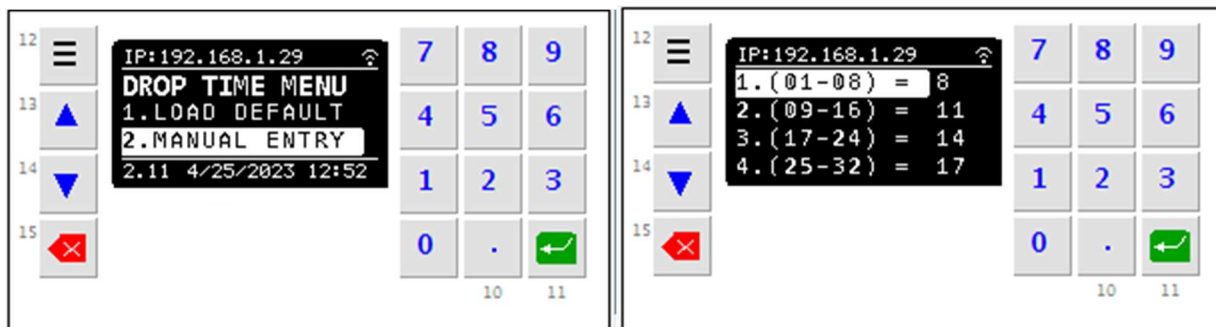

### 5.2.1.6 ENERGIZE TIME

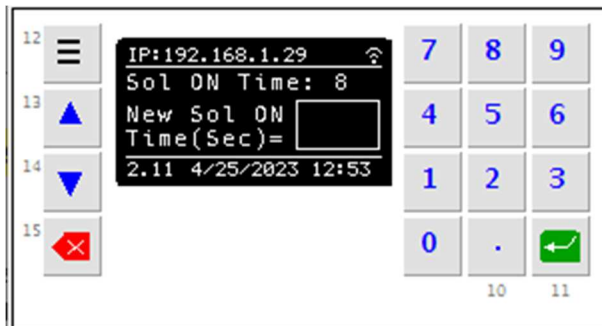

This setting indicates how much time the Solenoid will take to allow the user to open the door. Typical is 4 Seconds, Max Time is 8 Seconds, unless factory set to a different time due the application.

### 5.2.1.7 DOOR ALARM INPUT

The DMS Controller uses this input on each board to determine the status of the Door if it is left open due to a mechanical issue or if an intentional situation. This is achieved by using a detector connected to each board. If The system detects this condition over 1 minute, it will trigger an Alarm and depending on the configuration it might lock all chute until this condition is resolved.

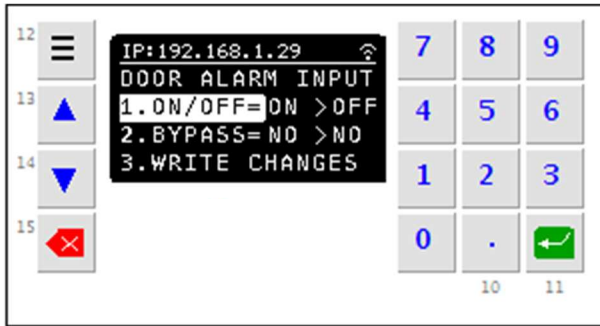

This Sequential Menu shows the Current > New Setting or each selection

1. ON/OFF = Enables/Disables the need of the Input
2. BYPASS = if enabled the previous setting this NO > YES option will allow the System to bypass the Alarm by the user
3. WRITE CHANGES = will set those parameters on Memory for operation.

### 5.2.1.8 ADDRESS LABEL

On Certain locations, we need to offset the traditional setting of address number = level number due multiple reasons, such building configurations, dual disposal intakes, lucky level numbers etc.

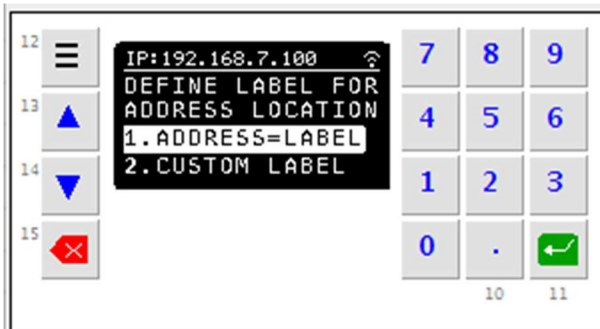

The option 1 ADDRESS = LABEL will set each address to be the Label displayed during the In Cycle Screen.

To define a custom Label Select option 2 and follow the below indicated Screens

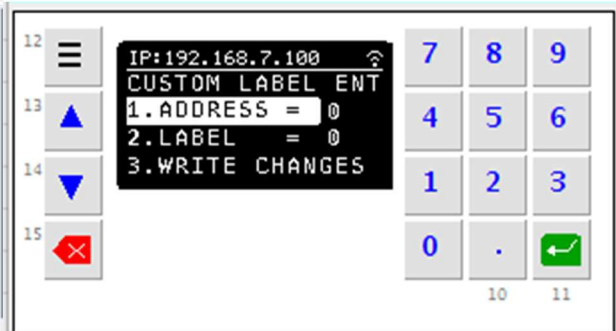
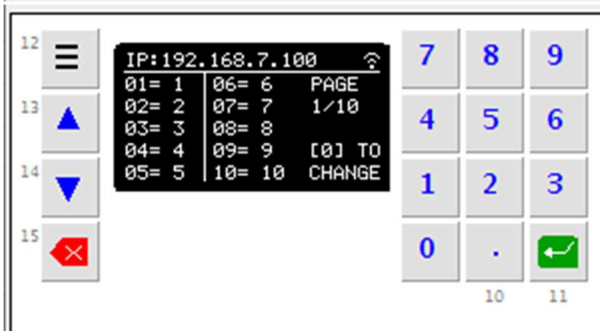

## 5.2.2 OPTIONS

Options are associated to the interconnection of other devices to the DMS Controller

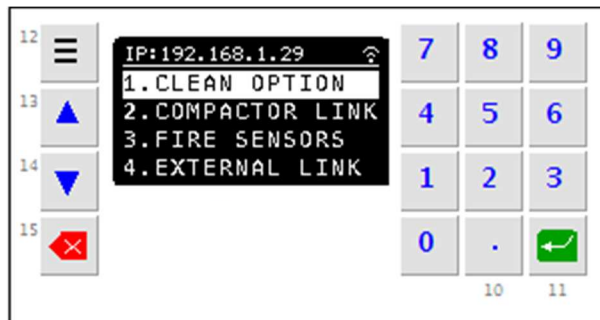

1. CLEAN OPTION = Operates the Interface to a Cleaning Address used for service purposes.
2. COMPACTOR LINK = Defines the interface to a Wilkinson Compactor connected to the DMS Controller using a specific address.
3. FIRE SENSORS = Defines the interface to the Chute Provided Normally Closed Smoke and/or Heat Detectors. This option also allows to send a signal to an external Fire Alarm System – refer to the specific wiring diagrams for this.
4. EXTERNAL LINK = Defines the Bidirectional Interfaces to third party Building Management or Fire Alarm Systems. These systems will send signals to this external system through a board interface and / or receive signals from these systems causing the DMS to lock the doors.

Each Interface requires the use of an independent board, consult Wilkinson on the best practices to accomplish these connections.

### 5.2.2.1 CLEAN OPTION – CONFIGURATION

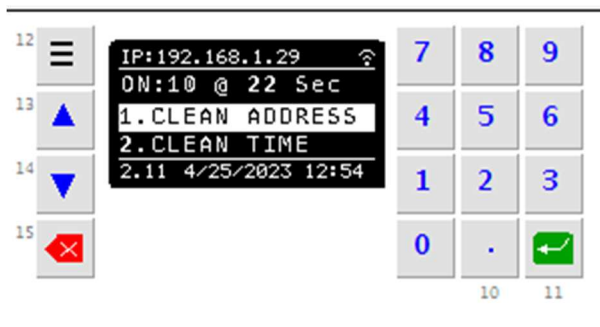

This option is defined as a “TIMED” output on a specific address.

CLEAN ADDRESS = is the address selected to be activated when the clean option is selected under the service menu

CLEAN TIME = is the time for activation of the CLEAN ADDRESS from 1 – 255 Sec.

### **WARNING !!!**

*Be careful to consider the water/clean used during this clean time to avoid flooding the trash room.*

### 5.2.2.2 COMPACTOR LINK – CONFIGURATION

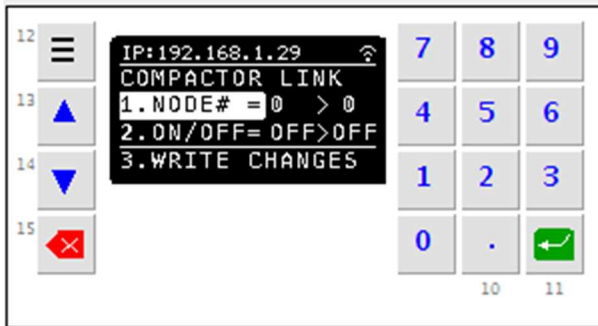

Use this option to indicate the address of the board used to interface with a Wilkinson Configured Compactor.

NOTE: If an External FAS and/or BMS Interface has been specified, this alarm will also send an Alarm to those external systems.

### 5.2.2.3 FIRE SENSORS INTERFACE (SMOKE/HEAT DETECTORS)

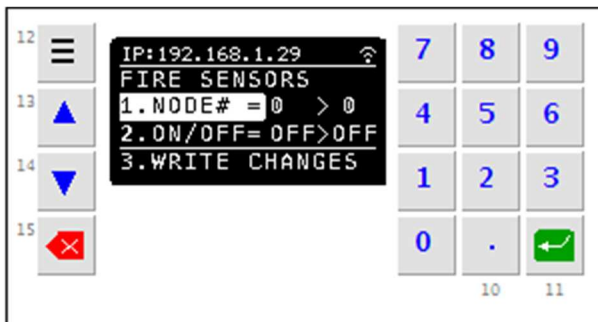

Use this option to define the address of the board used to link the smoke and/or heat detector to the DMS Controller.

NOTE: If an External FAS and/or BMS Interface has been specified, this alarm will also send an Alarm to those external systems.

### 5.2.2.4 EXTERNAL INTERFACES

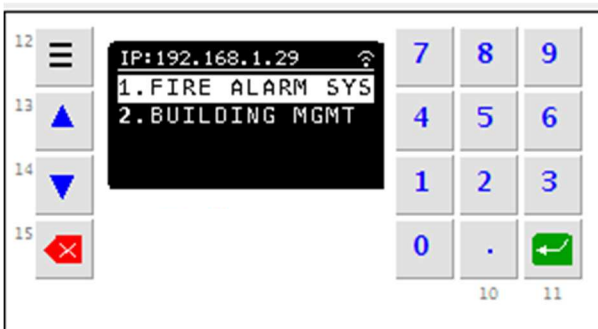

This is third party field connected system by others that through a board interface can send and receive alarms to the DMS Controller.

Node = Board Address

SIGNAL = Feedback Signal from DMS to BMS/FAS external interfaces

ON/OFF = Enable or Disables the Interface

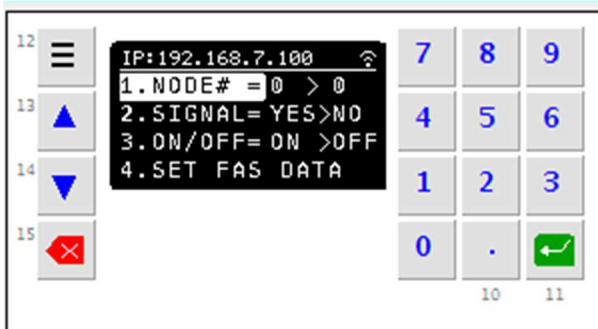

SET FAS = Fire Alarm System

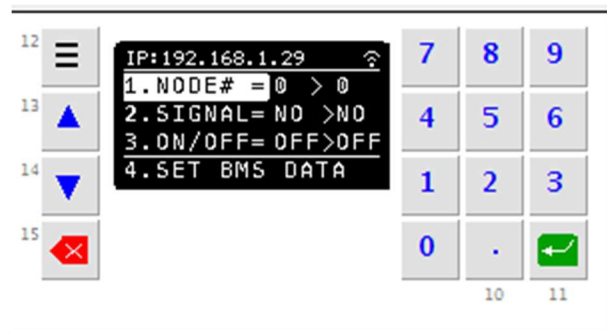

SET BMS = Building Management System

## 5.2.3 SYSTEM

System Options are settings used to operate the system, usually done only during system configuration start up or troubleshooting.

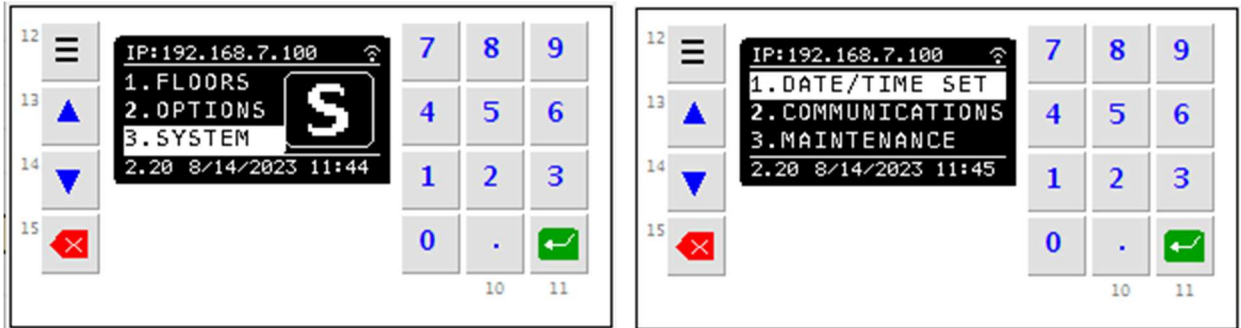

### 5.2.3.1. CONTROLLER DATE/TIME

Self-explanatory is used to set the controller Date / Time, this is initially set at the factory during Testing, but it can be manually Set by using the SET TIME/SET DATE Options and then entering the appropriate numbers or Sync with an Internet Time Server to the default CDT (Central Daylight Time zone)

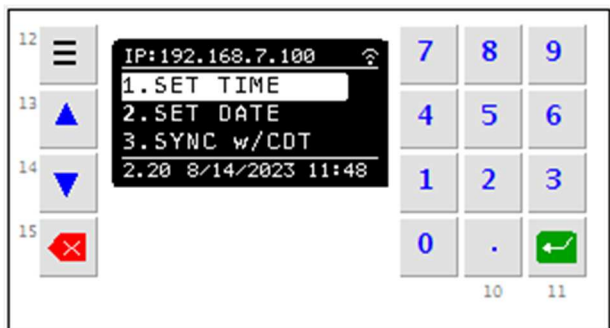

System Date/Time is shown at the bottom of certain screens for user review.

### 5.2.3.2. COMMUNICATIONS

The DMS Controller can connect to the Internet to interact with the Central Wilkinson Servers, receive updated firmware, and send email notification alarms to defined users.

WIFI communication is required to achieve this feature. (2.4 GHZ ONLY). Refer to the wiring schematics section for Ethernet-WIFI Controller connections.

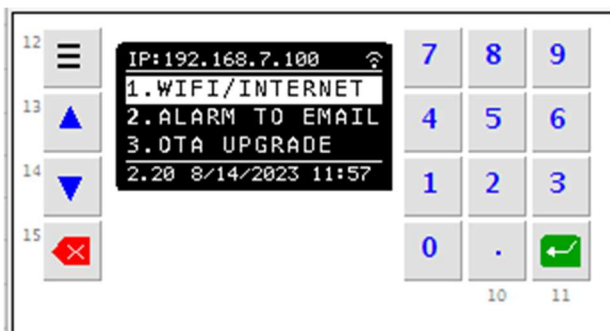

1. WIFI/INTERNET Defines the connection to the field WIFI and Remote Control
2. ALARM TO EMAIL- Defines the Email addresses associated to the controller for alarm notification.
3. OTA UPGRADE = Over the Air Upgrade this is a password protected feature to update the program of the controller

### 5.2.3.2.1 How to connect to the Field WIFI Network

Prerequisites:

- WIFI 2.4 GHZ needs to be close to the DMS Controller.
- SSID to be known (Service Set Identified) AKS Name of the WIFI Network
- SSID Password to be known.

If not WIFI is at the Controller Location, a Ethernet – WIFI Add-on accessory can be implemented – refer to Wilkinson for information.

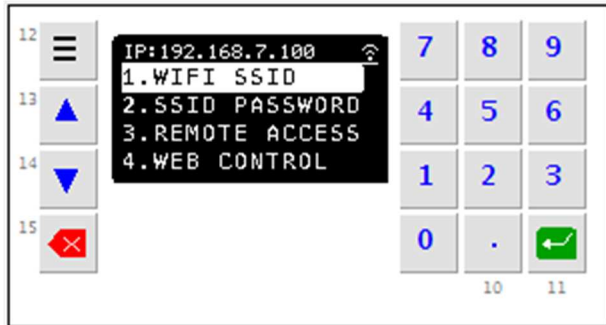

1) Select WIFI SSID to enter the Name of the WIFI Network, see below screen to enter the information requested.

2) Select SSID Password and when finish select the option Reboot the controller.

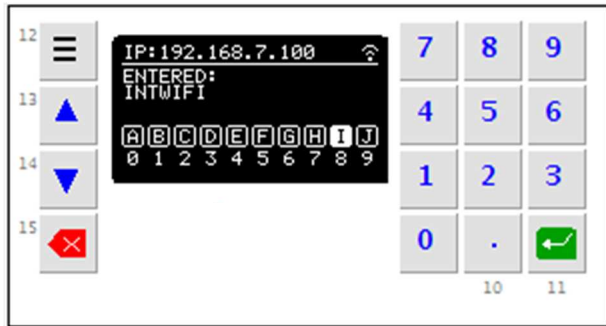

These alphanumeric screens are used to enter passwords, and names, the bottom numbers indicate the keypad entry and the above squared indicates the value of the key. Use the keys to move the letters to key values. The Entered Strings shows on top of the screen.

When WIFI is properly connected to the system it will indicate the IP address assigned to the controller on the upper section and in the top right corner of the display the WIFI strength Symbol will appear.

#### NOTE

Internet Setup might need additional configuration/data from your IT Department or ISP Supplier. Please contact Wilkinson during the one-time Setup for configuration support.

### 5.2.3.2.2 EMAIL NOTIFICATIONS

The DMS controller can send email notifications once internet connectivity has been properly configured. One Email address has to be defined on the system in order to use it to send such notices.

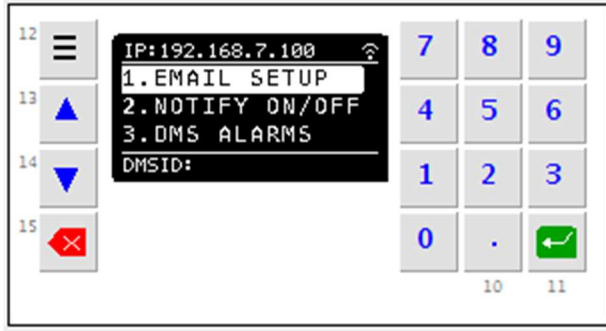

EMAIL SETUP = Self-explanatory, this is where you set the email address and you can Test the connectivity on this option

NOTIFY ON/OFF = Allows you to select which alarms/conditions you wish to be notified via email address

DMS ALARMS = Specific Options to the DMS Controller

DMSID = DMS Controller ID, is a string that you can define on DMS ALARMS Option to identify with a friendly common name the Controller.

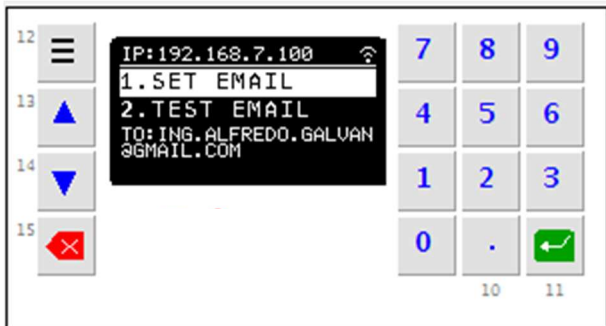

**EMAIL SETUP SCREEN**

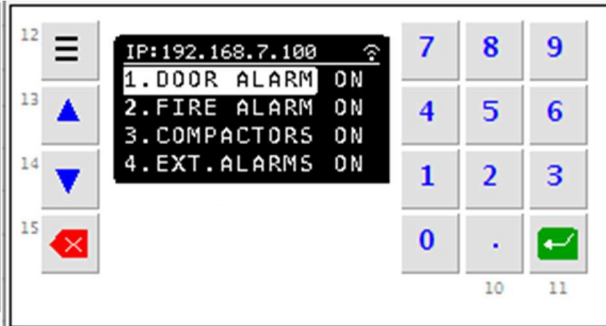

**NOTIFY ON/OFF ALARMS**

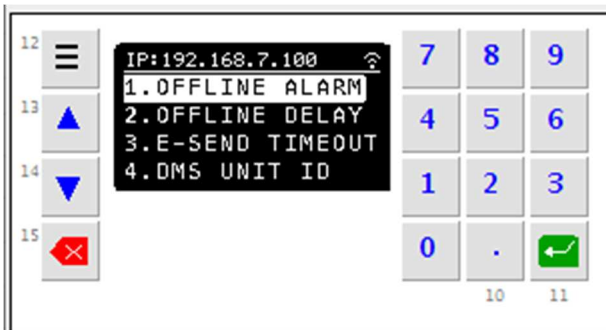

**OFFLINE ALARM:** On/Off, if ON will send you an email indicating that the controller has been out of SYSTEM READY for the

**OFFLINE DELAY:** Defined in MINUTES

**E-SEND TIMEOUT:** Is a delay in seconds to send an DMS Related Alarm to avoid false alarms

**DMS UNIT ID:** Set a Friendly name for the DMS Location

### 5.2.3.2.3 OTA UPGRADE

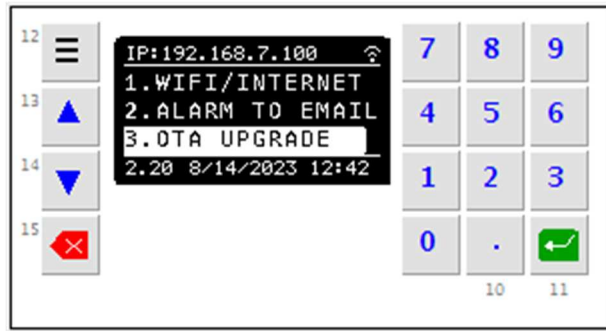

OTA Stands for “Over the Air” upgrade, if the system is properly setup to the internet and communication to the Wilkinson Central Server is properly configured, the system can remotely upgrade its program for upgrades, or programming issues.

Note that this is a password protected section, and the passcode needs to be given by Wilkinson Prior use.

**WARNING !!!**  
*An Over the Air Upgrade might delete certain site parameters so it is important to write down any specific configurations such as top address, interfaces address etc. etc.*

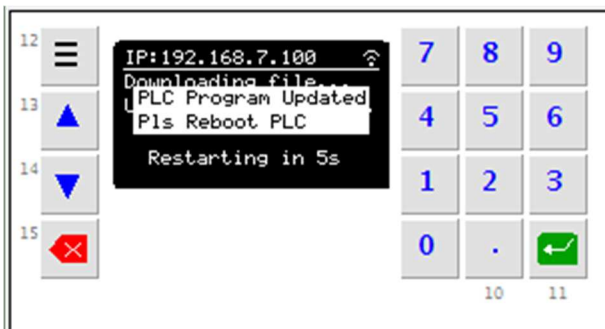
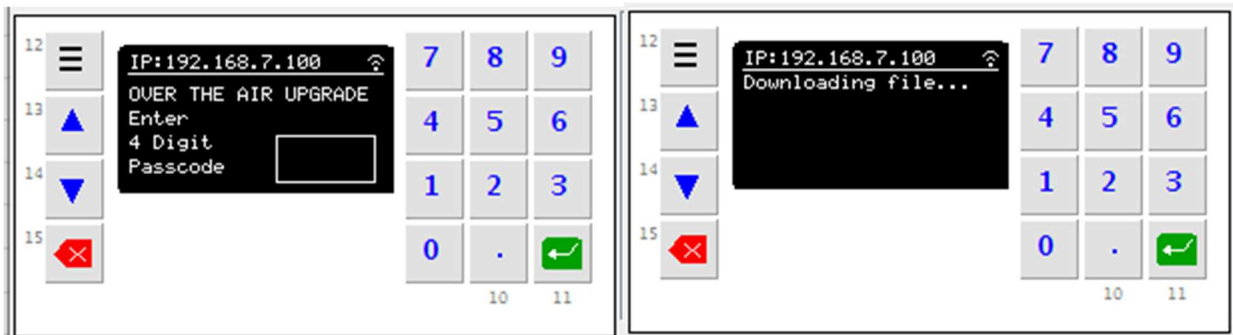

If connection is made correctly to the Central Wilkinson Server, DMS will download the latest applicable program as per the entered PASSCODE received from Wilkinson and will reboot the controller.

If otherwise, please contact Wilkinson for assistance.

### 5.2.3.3 MAINTENANCE

**WARNING !!!**

*Only experienced personnel should attempt to install, service, or operate this equipment. Installing this equipment requires the installer to work with high voltage electrical connections, which can cause serious injury or death.*

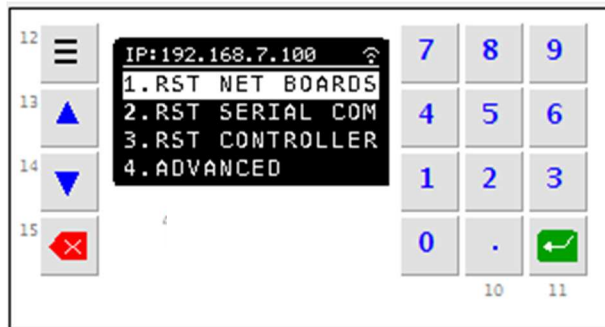

Maintenance options are used for troubleshooting and advance functions for diagnostics. They are included here for reference.

- 1) RST (RESET) NET BOARDS = These options reset the communications of all connected boards. Use this option when changes have been made to them such as replacing a board or replacing a connecting wire.
- 2) RST (RESET) SERIAL COM = This option resets the Controller Communication to the boards, Use it under specific request from Wilkinson Tech Support
- 3) RST (RESET) CONTROLLER = Self Explanatory – Resets all and reboots the controller – Use this when a change on memory is not read
- 4) ADVANCE – Reserved for Wilkinson Tech Support

**HARDWARE RESET** – Usually this is done by disconnecting power to the system and reconnecting it after 5 seconds.

**SYSTEM INTEGRITY CHECK** – System automatically checks its integrity 4 times a day performing a hardware reset to fix any unresponsive component due to a power variation, lighting, or unexpected event.

## 6. SYSTEM OPERATION

### 6.1 READY STAND BY SCREEN

This is the default screen of the system. Upon Startup the System will get into the ONLINE READY Mode after the initial checkups.

This screen will dim after 5 minutes of inactivity and will turn off if no input is received from the user interface or from any connected device after 16 minutes.

Screen will appear again upon a signal interaction is received.

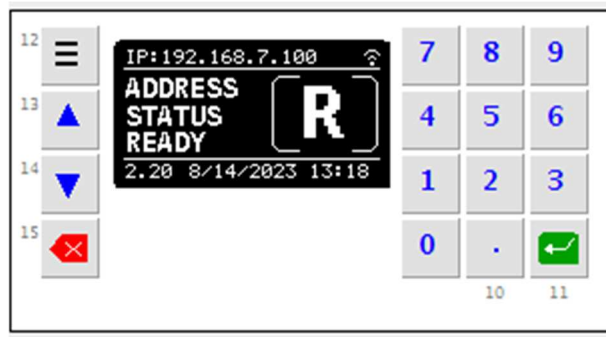

At the top of the controller is the IP Address and the WIFI Symbol indicating that internet connectivity has been configured.

The Letter “R” enclosed in the [ ] indicates that system is ready to receive disposals.

Bottom Left corner is the Program Revision and to the right system date and time.

### 6.2 SYSTEM IN CYCLE

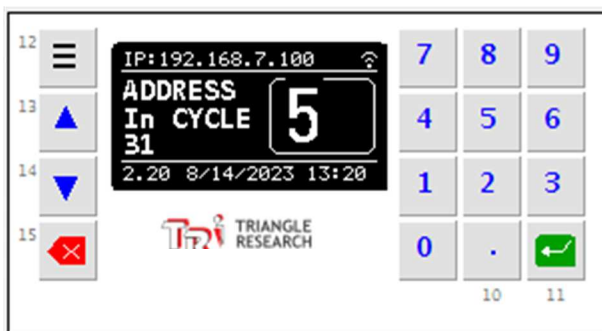

The DMS allows a single Door to be operated at a time, at each level the system is provided with a Keypad Membrane with options.

To allow access to open the door and throw disposal down the chute, the user must press the desired button for 1 sec to request the access to the DMS Controller

The DMS Controller screen will indicate the Address In Cycle as “5” on this case and show the upper edge of the rectangle open, and the seconds remaining of the cycle.

## 6.2.1 DOOR LEVEL KEYPAD

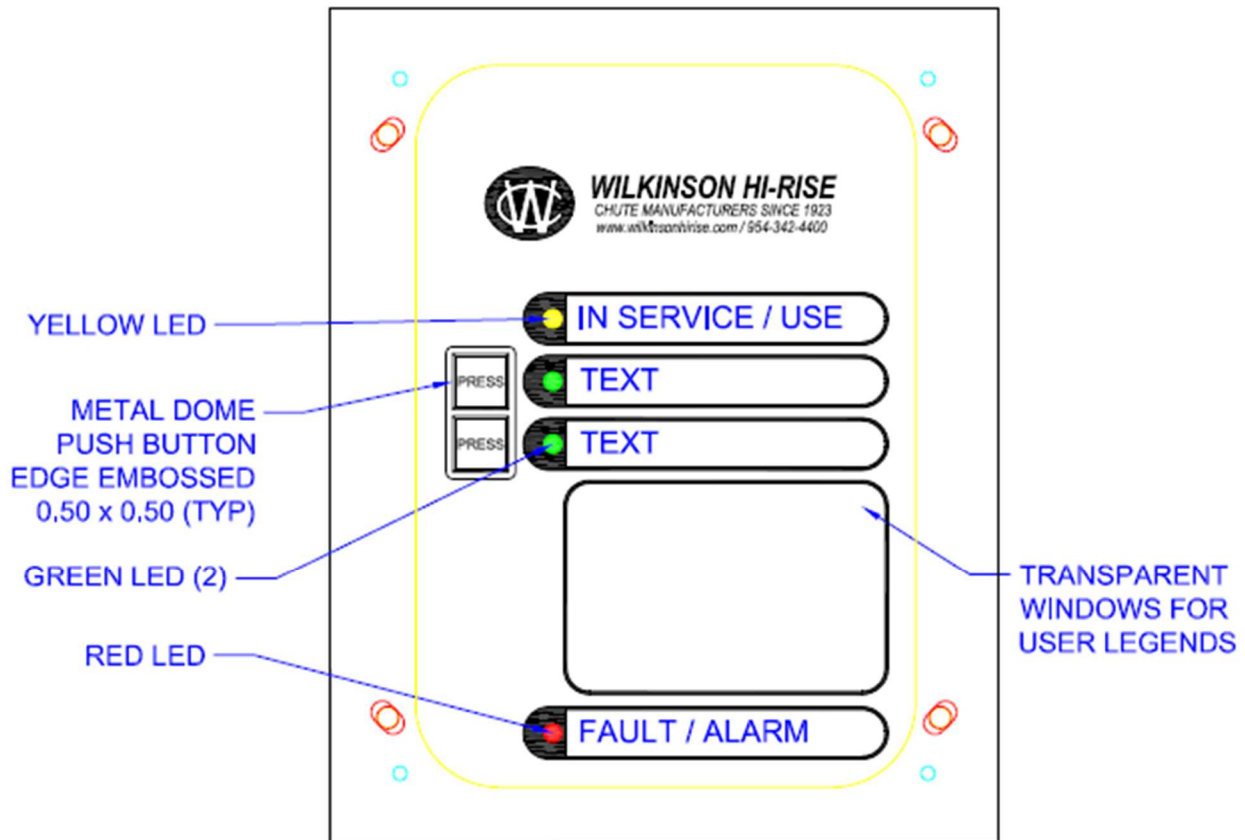

At each level, you will find a Similar Keypad as the above picture, this standard version consists of two buttons which can be used independently and by pressing them for 1 Sec, it will activate the cycle. The red light will briefly blink and been as an indication of acceptance.

After this event and during the duration of the Drop time, all other Doors will have the yellow/orange Led at the top indicating that the system is "IN USE" inhibiting the activation of other door until the door in cycle is completed.

In Use and the First Led on the Keypad will stay lit indicating that as the current door in cycle.

If the system is not ready because it is in service mode or in configuration mode, the Keypads on ALL doors will have the RED LIGHT ON indicating Fault/Alarm.

If there is an ALARM on the system, the RED LIGHT (FAULT/ALARM) will also stay lit on each door

## 6.2 SYSTEM IN SERVICE MODE

During Service Mode, the system will LOCK ALL DOORS to avoid the end user at the floor level accessing the chute. The Large boxed “S” on the System Screen will remind of that condition.

This is the Mode that the Building Maintenance personal needs to set the DMS Controller prior to performing any cleaning or container changeover at the chute.

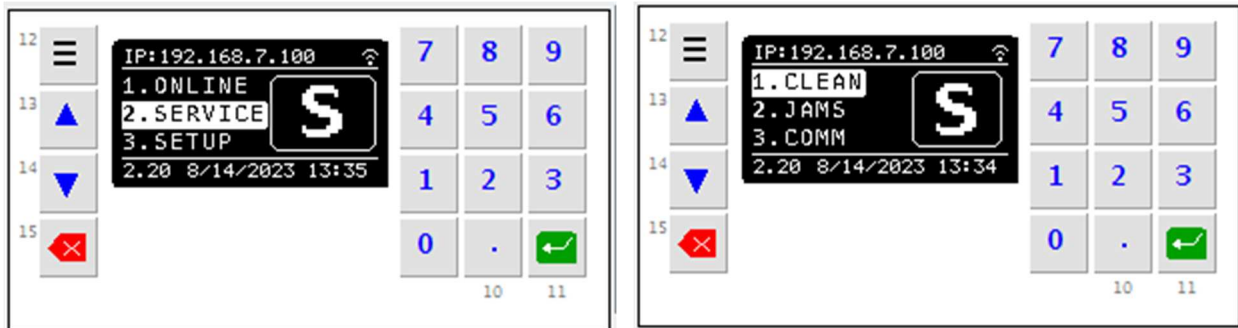

DMS Controller operations that can be executed on this mode are:

1. CLEAN – Activate the Flush/Clean valve for washing down the chute system.
2. JAMS – Review if any door is held open on the system (this can be done if bypass is activated)
3. COMM – Review if system communication has any issue.

### 6.2.1 CLEAN OPERATION

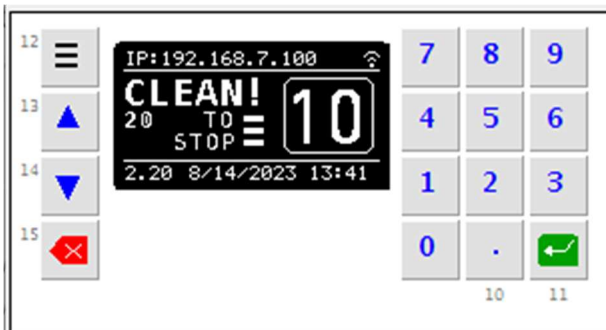

Upon Selecting this option, the DMS Controller will command the predefined Board Address for (on the picture shown 10), for the time specified on the configuration (20 seconds) on this picture.

If cycle needs to be stop at any point, press the Menu Button

When using this feature, make sure that the proper chute valve is connected to the board specified for that purpose. Maximum Clean time is 255 seconds.

### **WARNING !!!**

*The trash room needs to be properly prepared to receive this cleaning water into the building sewer system.*

## 6.2.2 JAMS

A jam is defined as a Door that did not close properly, due to a mechanical issue, user jam action or another unknown reason. The system will show an alarm indicating the Door in Jam. (See below Left picture) if configured for bypass by pressing the MENU button, the systems will allow to continue operating with a message at the bottom of the display.

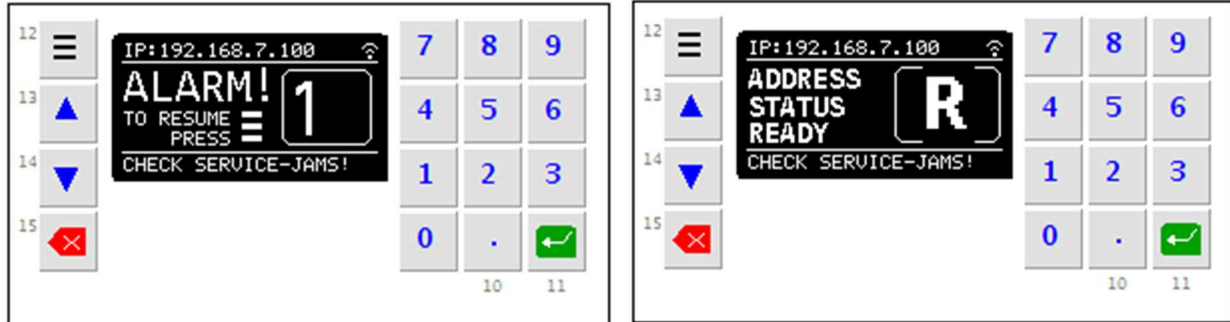

When the system has bypassed an alarm to continue operating the system, you can come to the Service Mode – JAMS Option to see which doors are in this condition and review the problem at the door level.

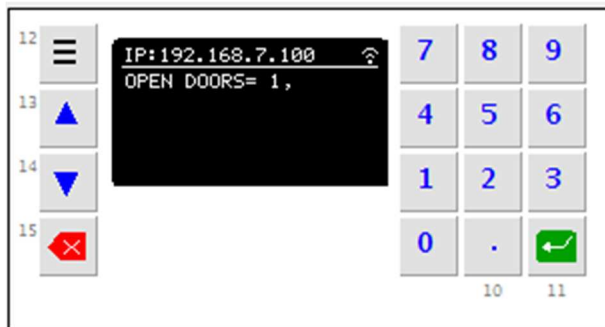

Once Problem is resolved, the message "Check Service-Jams" will disappear from the bottom screen.

## 6.2.3 COMMS

When the DMS Controller has issues with communication to the doors, due to an initial setup or damages the SERVICE – COMMS option will allow the controller to review its communication integrity with the doors.

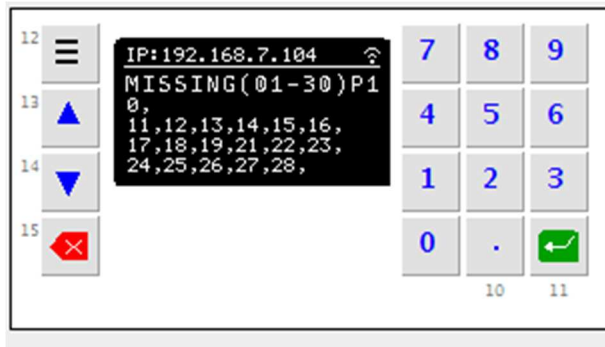

By selecting this option, the controller will display a list of the MISSING Addresses, meaning that the DMS Controller cannot establish communication with.

## 7. TROUBLESHOOTING AND MAINTENANCE

### 7.1 RECOMMENDED MAINTENANCE AND GENERAL ERRORS

DMS controller was designed to be a simple to maintain appliance system. It is not field serviceable and in case of a failure we need to cover the basics.

Cleanliness and good housekeeping need to be maintained around the controller.

#### **COMMON ISSUES**

- 1) DISPLAY IS OFF – Press an arrow button, most likely display is in power saving mode.
  
- 2) DISPLAY DO NOT RESPOND TO ANY BUTTON
  - ✓ Make sure that the power outlet is energized – check building circuit breaker.
  - ✓ Make sure the Power Plug is connected to the power outlet and there is no damage along the connecting cable.
  - ✓ Check AC Fuse 6A, Disconnect Power, then press and turn to remove it, make sure it is not blown.
  - ✓ Check DC Fuse 6A, Disconnect Power, then press and turn to remove it, make sure it is not blown.
  
- 3) NO IP ADDRESS, NO WIFI SYMBOL AT TOP OF SCREEN
  - ✓ Internet Connection not setup – Configure Connection
  - ✓ Internet Interface Adapter is not power on or misconfigured
  
- 4) NO DATE/TIME AT BOTTOM OF THE DMS SCREEN
  - ✓ No Date has been Set, No Internet to Sync Date/Time – Manually Set
  
- 5) FLOORS KEYPAD NOT POWERED ON
  - ✓ Configuration change has not been read by controller, turn power off and wait for 5 seconds, restore power and check.
  - ✓ Check DC Fuse, Disconnect Power, Press and turn to remove it, make sure it is not blown. If this blows up again, Disconnect EtherCAN Cable to doors, possible Cable Damage upstream the chute.

## **SYSTEM GENERATED ALARMS**

Alarms triggered by the system sensors, or systems will indicate on the display, will lock the system and the RED LIGHT on all doors will blink indicating an Alarm – Solid RED LIGHT Indicates SERVICE MODE.

Instructions given on each screen might let you bypass the condition if it has been configured, but a legend at the bottom of the screen will indicate an existing alarm condition.

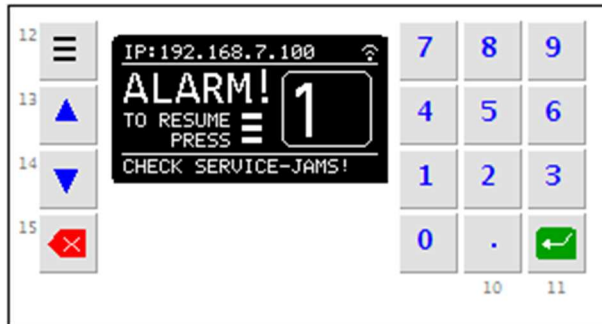

This ALARM indicates that the Door on Address Board 1 has been left open due a mechanical malfunction. By Pressing the MENU Button, you can continue operating. User Service Mode – JAMS to see how many doors got this condition.

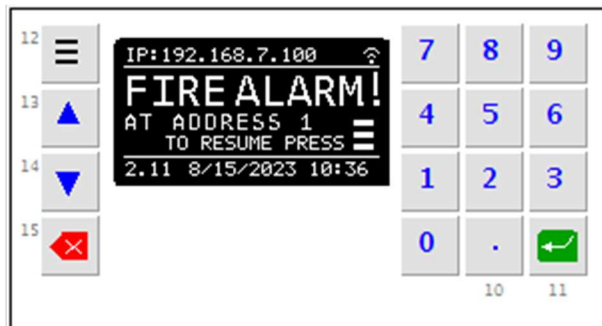

Fire Alarm triggered by the Smoke and/or Heat Detector connected to the system. This is a Normally Closed Signal – missing the connection to the interface board will trigger this alarm. IF FAS/BMS has been configured with Feedback, this alarm will send a signal to external system.

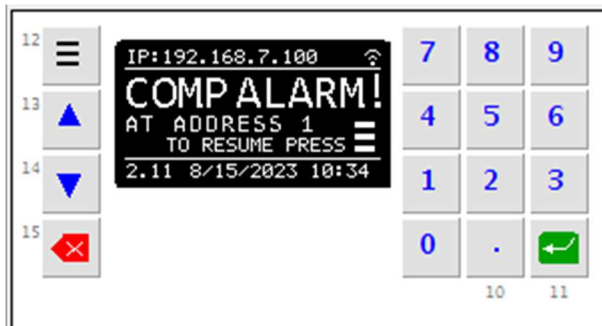

Wilkinson Compactor connected to the DMS through a UCB Interface has sent the signal of NOT READY. This is a Normally Closed Signal, - false connection can trigger this Alarm – Check the compactor status for troubleshooting. IF BMS has been configured with Feedback, this alarm will send a signal to external system.

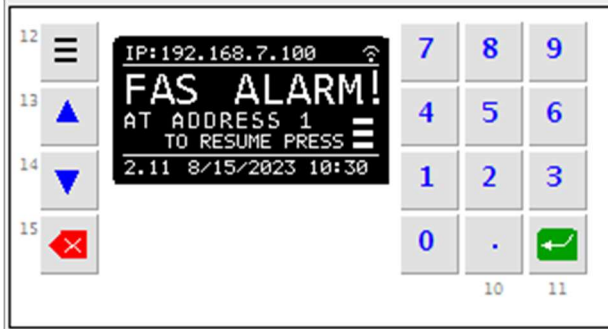

This message displays when the external Fire Alarm System Configured to the specified address received a signal. This is a normally OPEN Signal. DMS will lock all doors - Review External System. IF BMS has been configured with Feedback, this alarm will send a signal to external system.

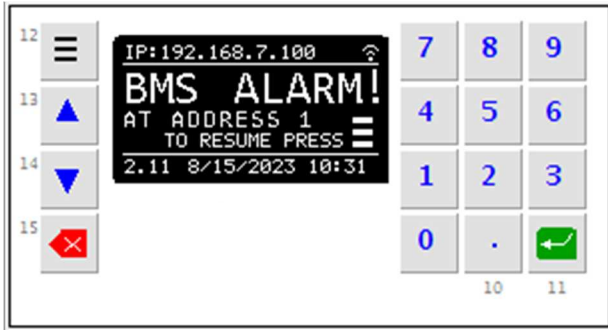

This message displays when the external Building Management System Configured to the specified address received a signal. This is a normally OPEN Signal. DMS will lock all doors - Review External System.

## **EMAIL GENERATED MESSAGES**

If DMS is properly set up with an email address and internet connectivity, messages also will get sent via email.

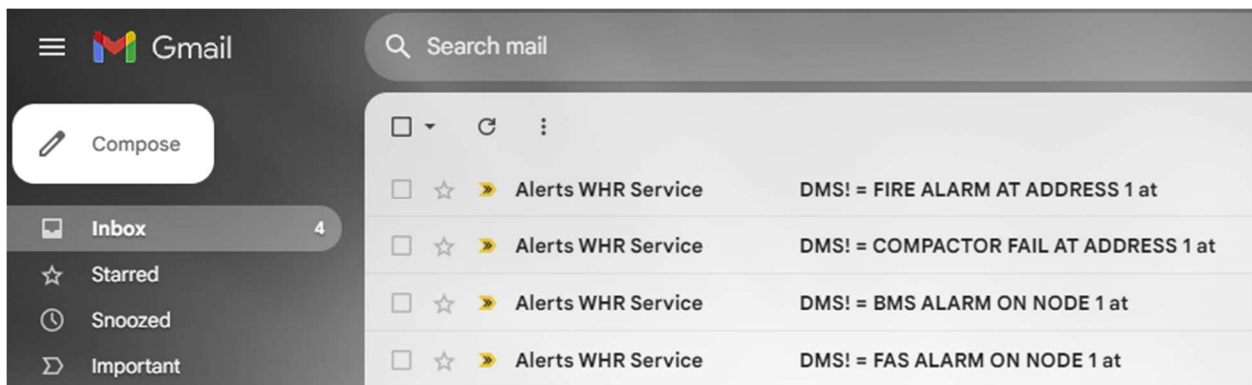
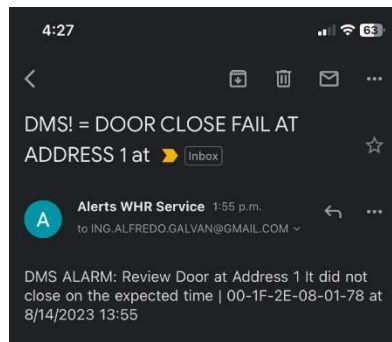
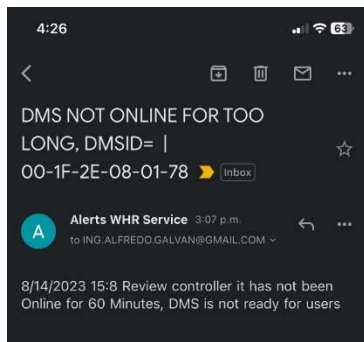

## **8. DRAWINGS, SCHEMATICS, ATTACHMENTS**

### **INDEX**

**8.1 DMS CONTROLLER PORTS**

**8.2 SPARE PART LISTS**

**8.3 DMS SCHEMATICS**

**8.4 DMS INTERFACES WITH FIRE SENSORS & COMPACTOR**

**8.5 DMS INTERFACES WITH EXTERNAL SYSTEMS**

**8.6 APPLICATION TREE**

## 8.2 DMS CONTROLLER PORT

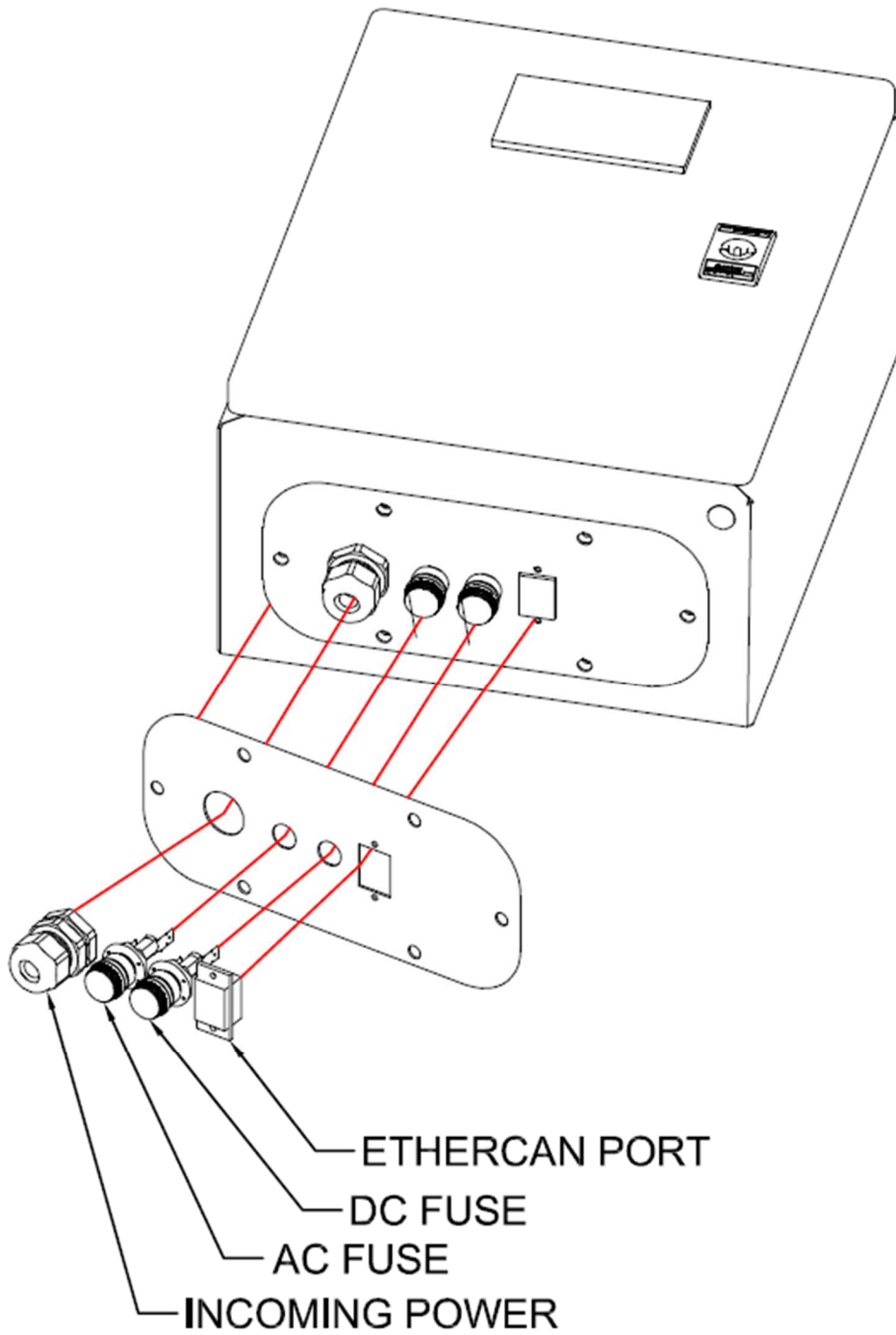

### 8.3 DMS CONTROLLER SPARE PARTS LIST

The DMS Controller is not serviceable by end user, if an electrical problem happens two fuses can be replaced to see if it was a temporary issue.

PART NO.	SPEC	DESCRIPTION	LOCATION
91A237	GMA-6	AC FUSE 6A	BOTTOM CENTER LEFT
91A237	GMA-6	DC FUSE 6A	BOTTOM CENTER RIGHT
91A703		DMS CONTROLLER	

# CONDUIT LAYOUT TO DOORS FOR THE DOOR MANAGEMENT SYSTEM [DMS]

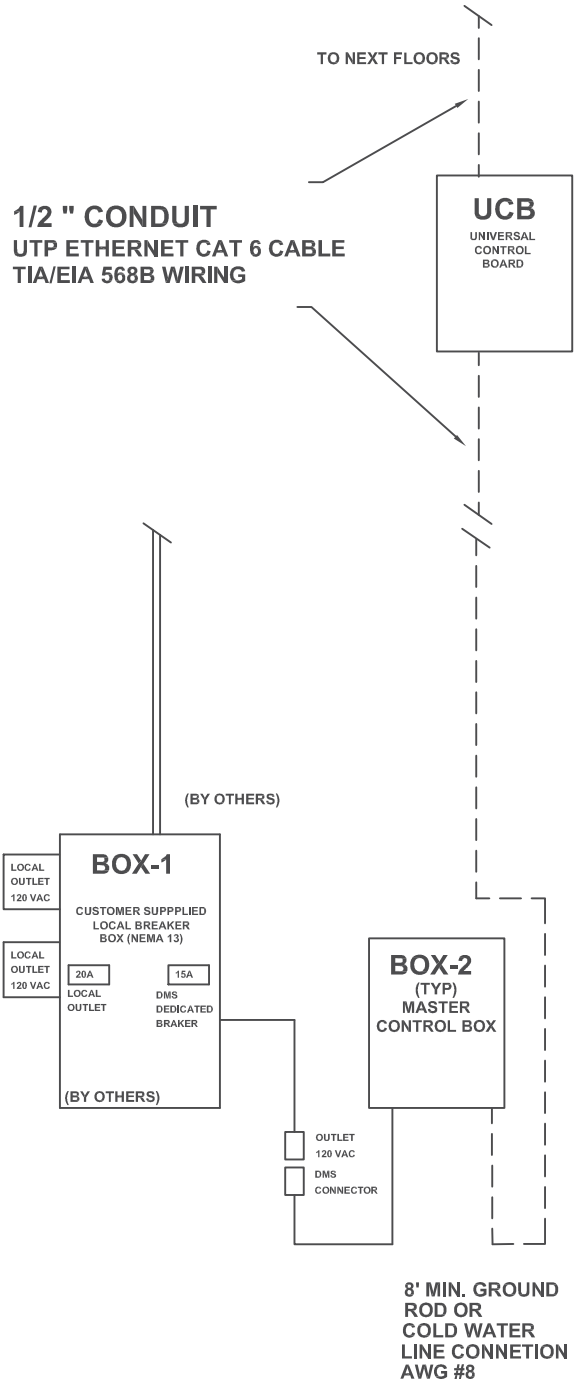

JOB No. / Name:	DATE	DESCRIPTION	REV BY	REV LEV
Customer:	8.15.2023	INIT	AG	A
	8.29.2023	ISSUED	AG	A

**WILKINSON-HI-RISE**  
 3402 SW 26th Street Terrace Unit B-10  
 Dania Beach, FL 33312  
 Ph. 954 342 4400 , Tech Support 830 584 1249

---

**DMS/UCB - INSTALLATION GUIDELINES**

DMSUCB81523    SCALE NTS    SHEET 1 OF 1

This Drawing is the property of WILKINSON HI-RISE. It is loaned on the condition that it is not to be reproduced, copied or otherwise disposed of, and is not to be used in part to furnish information for the making of drawings, prints, or parts there of, the acceptance of the foregoing conditions and the recognition of the exclusive ownership in and to the drawings as the property of WILKINSON HI-RISE.

# NETWORK CONNECTIONS BY LEVEL

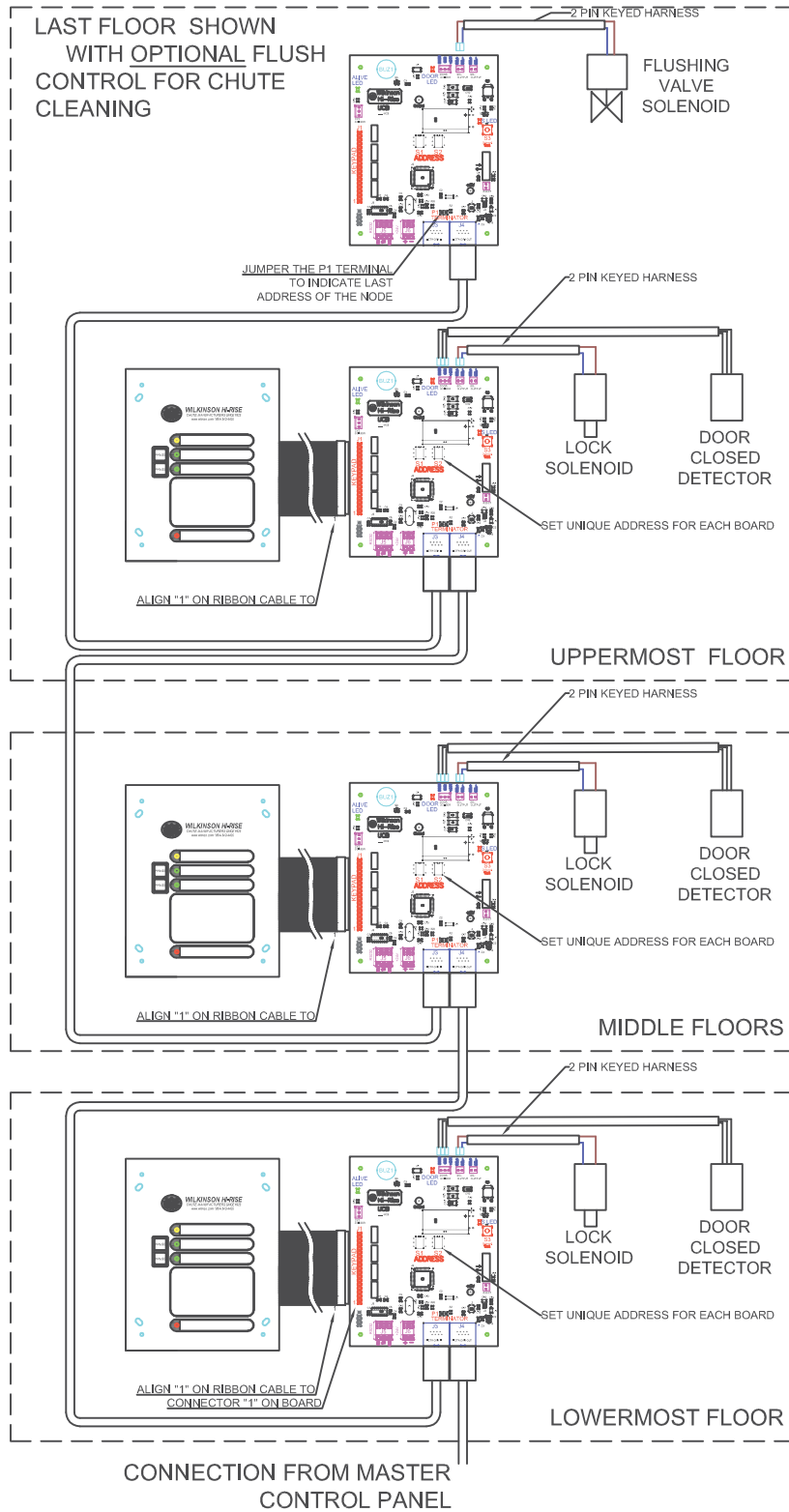

JOB No. / Name:	DATE	DESCRIPTION	REV BY	REV LEV
Customer:	8.15.2023	INIT	AG	A
	8.29.2023	ISSUED	AG	A
This Drawing is the property of WILKINSON HI-RISE. It is loaned on the condition that it is not to be reproduced, copied or otherwise disposed of, and is not to be used in part to furnish information for the making of drawings, prints, or parts thereof, the acceptance of the foregoing conditions and the recognition of the exclusive ownership in and to the drawings as the property of WILKINSON HI-RISE.				



**WILKINSON-HI-RISE**  
 3402 SW 26th Street Terrace Unit B-10  
 Dania Beach, FL 33312  
 Ph. 954 342 4400 , Tech Support 830 584 1249

DMS/UCB - INSTALLATION GUIDELINES  
 DMSUCB81523 SCALE NTS SHEET 1 OF 2

# AUXILIARY POWER BOOST OPTION

( to be installed after 20 Doors or 250 FT , Field Validated)

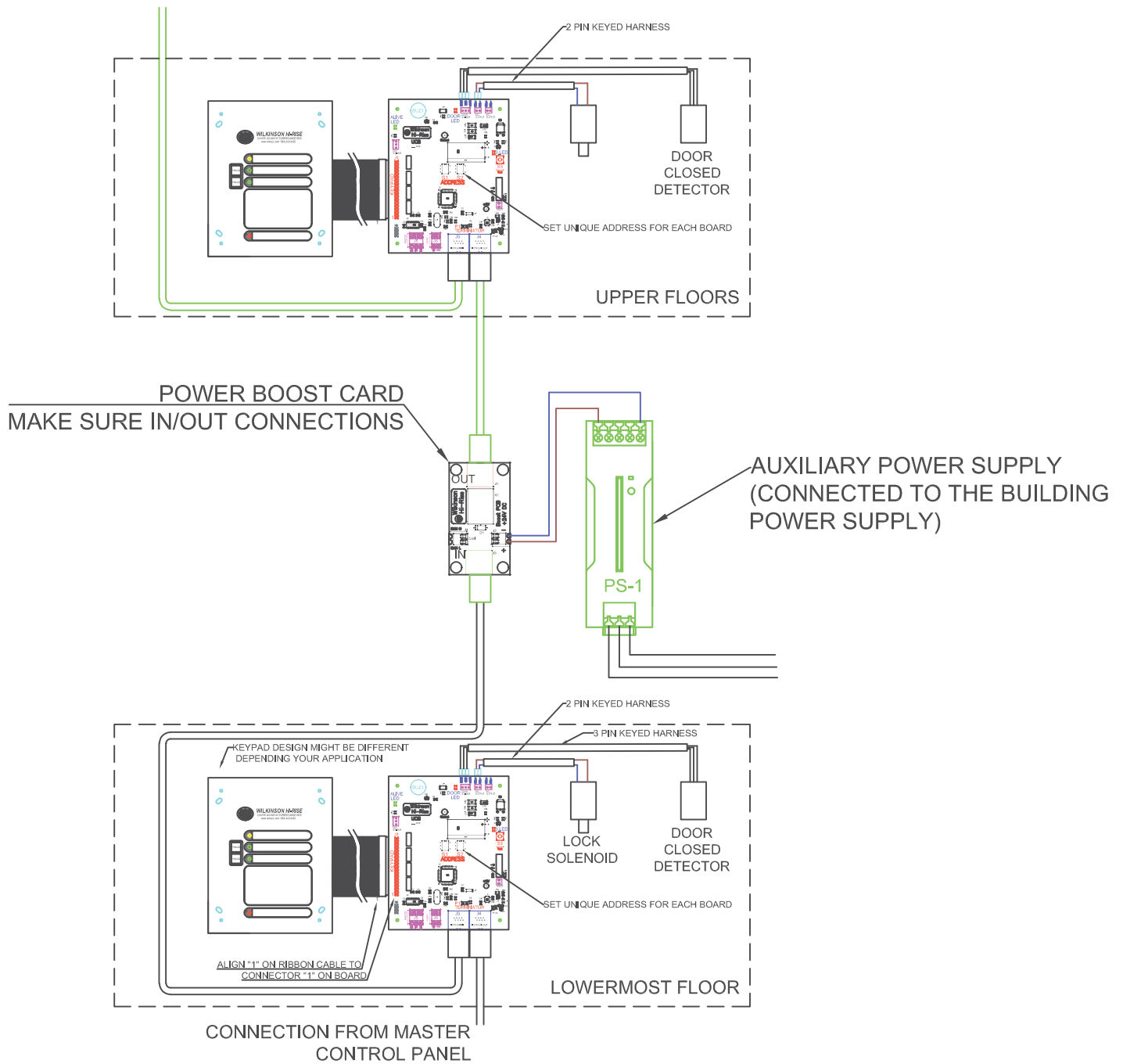

JOB No. / Name:		DATE	DESCRIPTION	REV BY	REV LEV
Customer:		8.15.2023	INIT	AG	A
		8.29.2023	ISSUED	AG	A
This Drawing is the property of WILKINSON HI-RISE. It is loaned on the condition that it is not to be reproduced, copied or otherwise disposed of, and is not to be used in part to furnish information for the making of drawings, prints, or parts thereof, the acceptance of the foregoing conditions and the recognition of the exclusive ownership in and to the drawings as the property of WILKINSON HI-RISE.					



**WILKINSON-HI-RISE**  
 3402 SW 26th Street Terrace Unit B-10  
 Dania Beach, FL 33312  
 Ph. 954 342 4400 , Tech Support 830 584 1249

DMS/UCB - POWER BOOSTER

DMSUCB81523

SCALE NTS

SHEET 2 OF 2

# UCB2 - UNIVERSAL CONTROL BOARD REV 2

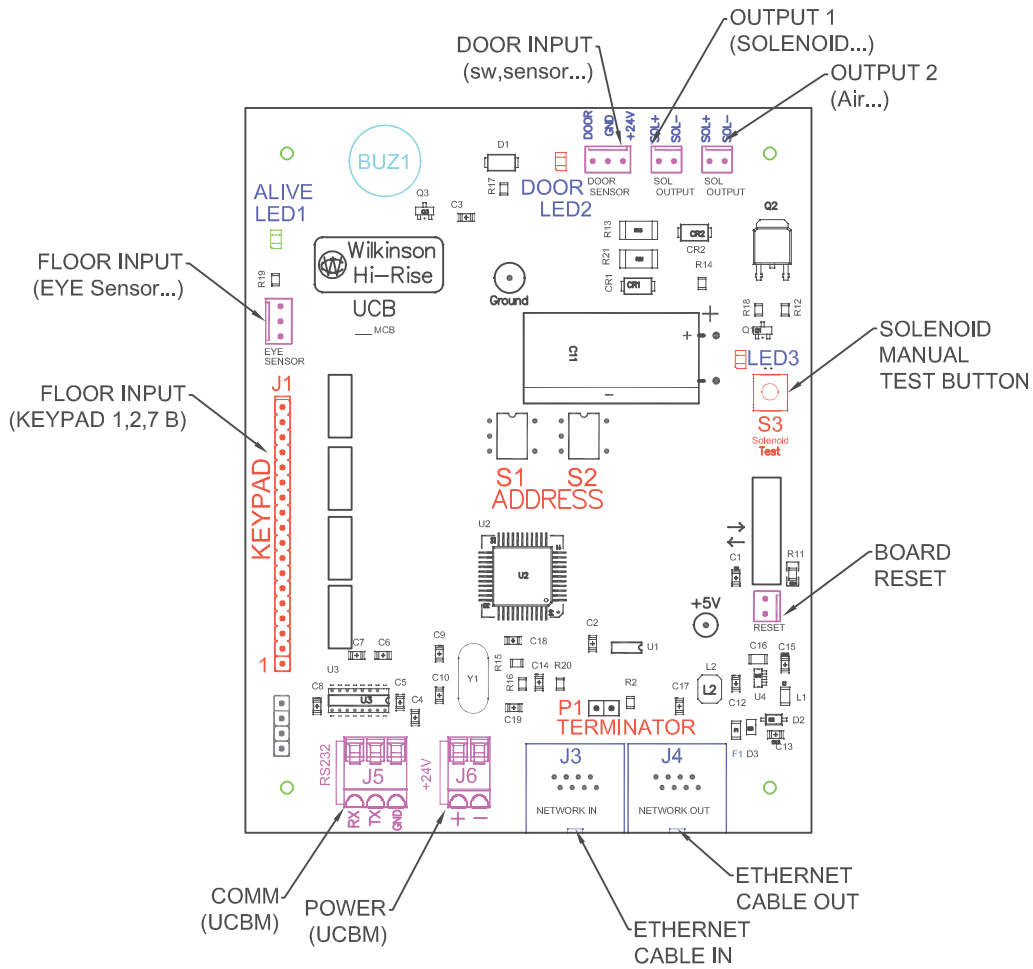

**UCB2 FEATURE DESCRIPTION**

LABEL	DESCRIPTION
J1	FLOOR INPUT -Keypad Connection for Intake Door(Note Pin 1 Orientation)
EYE SENSOR	FLOOR INPUT - Sensor Input 24VDC POWER PNP - 2 / 3 WIRE OPTION - USE 3 pin KEYED HARNESS
DOOR INPUT	24 VDC DOOR INPUT 2 / 3 WIRES - 3 PIN KEYED HARNESS - OPTIONAL
OUTPUT1	24 VDC FUSE PROTECTED BOARD OUTPUT - TYPICAL USE - LOCK SOLENOID - USE 2 PIN KEYED HARNESS
OUTPUT2	24 VDC FUSE PROTECTED BOARD OUTPUT - TYPICAL USE - AIR SOLENOID - USE 2 PIN KEYED HARNESS
J3 , J4	Ethernet Floor Connections LABEL AS NET_IN , NET_OUT
J5	COMM Port (UCBM ONLY)
J6	Power Connection(UCBM ONLY)
S1, S2	Board Address (Set on each intake, must be unique 00 - 99 )
S3	SOLENOID (J2) TEST PORT (Press for Temporary Test)
LED1	GREEN LIGHT - ALIVE - Will blink when Power On and Communication is established
LED2	RED LIGHT - DOOR - Solid when door input is being received
LED3	RED LIGHT - Solid when Outputs 1 or 2 are energized
BUZ1	Audible Door Signal
P1 TERM	TERMINATOR JUMPER - Install on the Last Board on the Chain
BOARD RESET	Short this pins to reset the board

JOB No. / Name:	DATE	DESCRIPTION	REV BY	REV LEV
Customer:	8.15.2023	INIT	AG	A
	8.29.2023	ISSUED	AG	A



**WILKINSON-HI-RISE**  
 3402 SW 26th Street Terrace Unit B-10  
 Dania Beach, FL 33312  
 Ph. 954 342 4400 , Tech Support 830 584 1249

DMS/UCB - UCB BOARD COMPONENTS  
 DMSUCB81523 SCALE NTS SHEET 1 of 1

This Drawing is the property of WILKINSON HI-RISE. It is loaned on the condition that it is not to be reproduced, copied or otherwise disposed of, and is not to be used in part to furnish information for the making of drawings, prints, or parts there of, the acceptance of the foregoing conditions and the recognition of the exclusive ownership in and to the drawings as the property of WILKINSON HI-RISE.

# UCB2 - SMOKE / HEAT DETECTOR CONNECTION

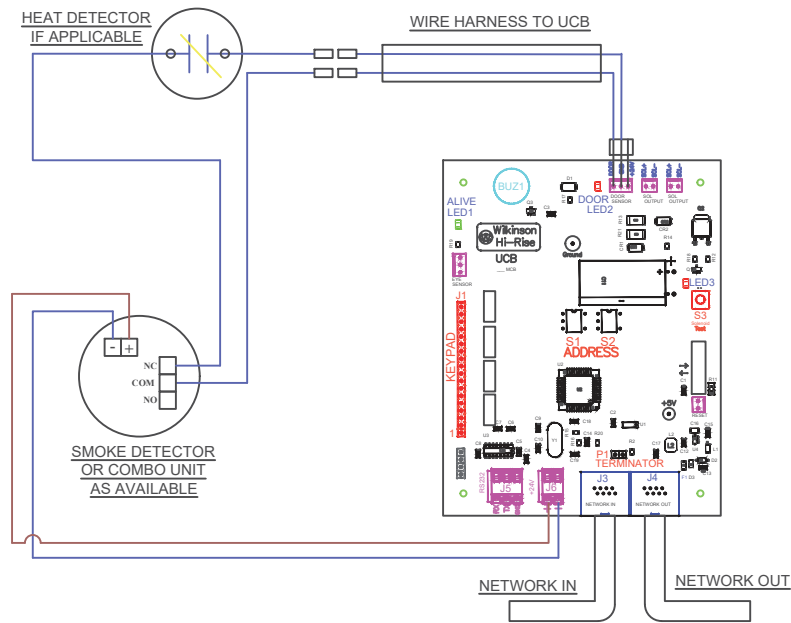

# UCB2 - COMPACTOR CONNECTION

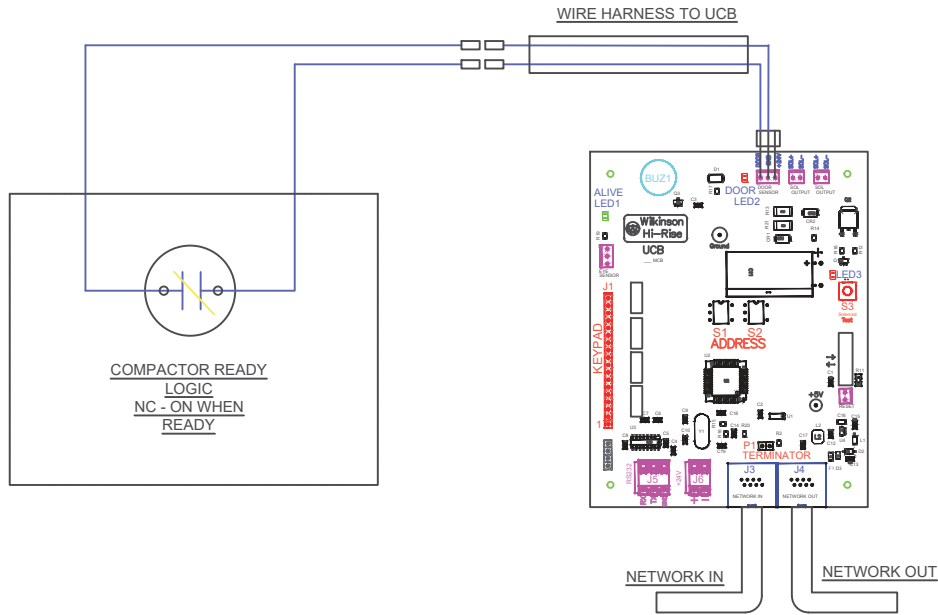

JOB No. / Name:	DATE	DESCRIPTION	REV BY	REV LEV
Customer:	8.15.2023	INIT	AG	A
This Drawing is the property of WILKINSON HI-RISE. It is loaned on the condition that it is not to be reproduced, copied or otherwise disposed of, and is not to be used in part to furnish information for the making of drawings, prints, or parts there of. The acceptance of the foregoing conditions and the recognition of the exclusive ownership in and to the drawings as the property of WILKINSON HI-RISE.				

**WILKINSON-HI-RISE**  
 3402 SW 26th Street Terrace Unit B-10  
 Dania Beach, FL 33312  
 Ph. 954 342 4400 , Tech Support 830 584 1249

**DMS/UCB - INTERFACES**  
 DMSUCB81523 SCALE NTS SHEET 1 of 1

# UCB2 - DMS - EXTERNAL CONNECTIONS

## UCB2 - BUILDING MANAGEMENT SYSTEM

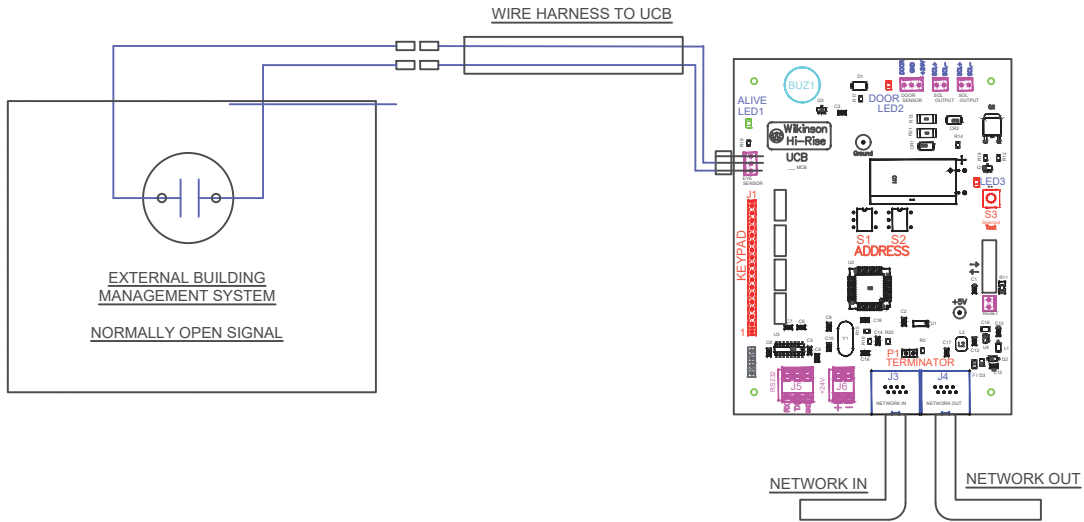

## UCB2 - FIRE ALARM SYSTEM

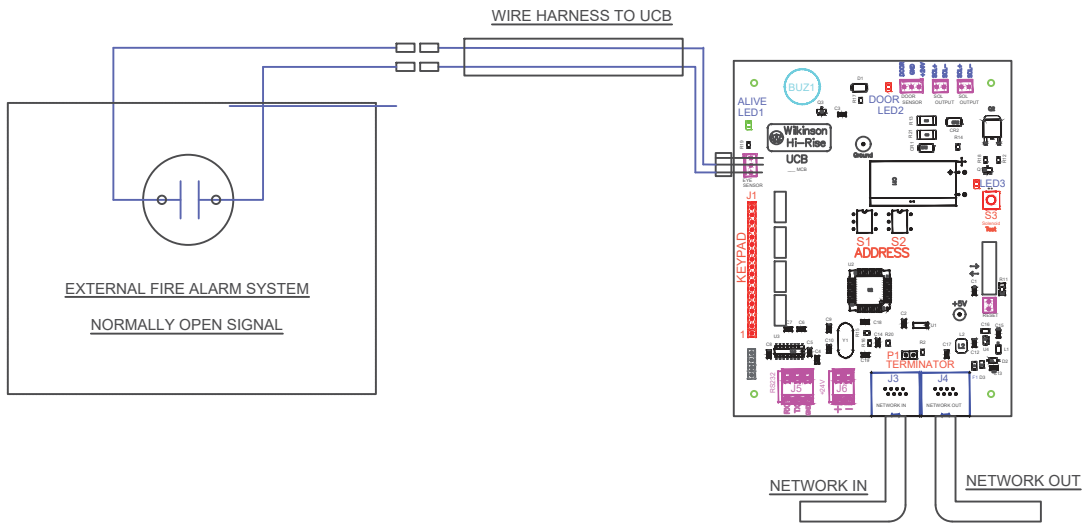

JOB No. / Name:	DATE	DESCRIPTION	REV BY	REV LEV
Customer:	8.15.2023	INIT	AG	A
This Drawing is the property of WILKINSON HI-RISE. It is loaned on the condition that it is not to be reproduced, copied or otherwise disposed of, and is not to be used in part to furnish information for the making of drawings, prints, or parts there of. the acceptance of the foregoing conditions and the recognition of the exclusive ownership in and to the drawings as the property of WILKINSON HI-RISE.				



**WILKINSON-HI-RISE**  
 3402 SW 26th Street Terrace Unit B-10  
 Dania Beach, FL 33312  
 Ph. 954 342 4400 , Tech Support 830 584 1249

DMS/UCB - INTERFACES  
 DMSUCB81523 SCALE NTS SHEET 1 of 1

# 8.1 APPLICATION TREE

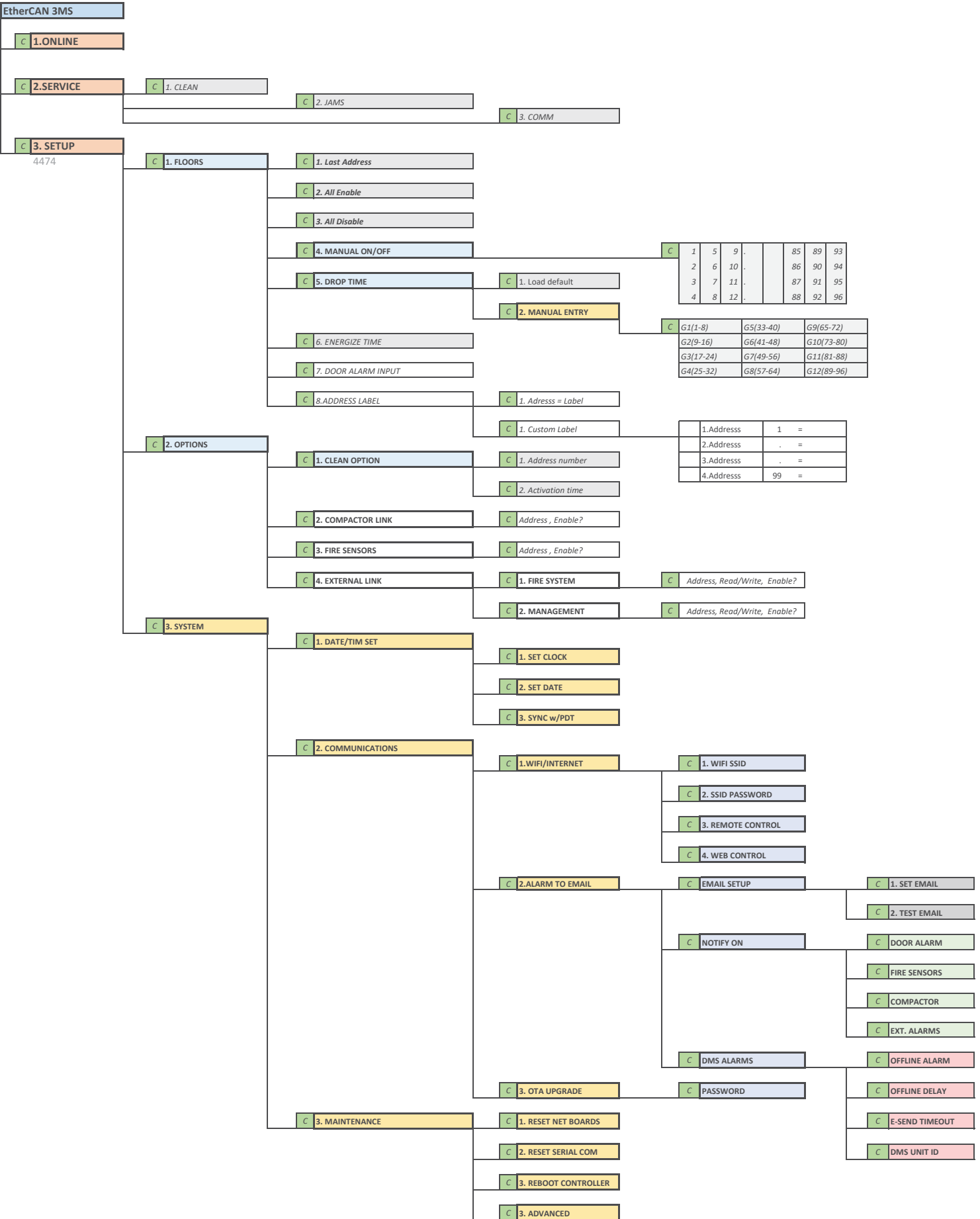

C	1	5	9	.		85	89	93
	2	6	10	.		86	90	94
	3	7	11	.		87	91	95
	4	8	12	.		88	92	96

C	G1(1-8)	G5(33-40)	G9(65-72)
	G2(9-16)	G6(41-48)	G10(73-80)
	G3(17-24)	G7(49-56)	G11(81-88)
	G4(25-32)	G8(57-64)	G12(89-96)

1.Address	1	=
2.Address	.	=
3.Address	.	=
4.Address	99	=